

Four-row linear recirculating ball bearing and guideway assemblies

with quad spacers or full complement



Quad spacers
for quiet running
Full complement
for maximum load capacity

Dynamic characteristics, high load carrying capacity, little space requirement, small moving masses, low-maintenance or maintenance-free, high operational reliability. These are the demands now made on linear bearing arrangements and are fulfilled to a greater or lesser degree by the various guidance system concepts available. In many applications, however, a further central characteristic has been added to these: *low-noise running*.

Low-noise guidance system

Running noise in linear guidance systems can be reduced by various methods. INA has decided to adopt plastic spacer elements – so-called QUAD SPACERS. One quad spacer accommodates two rolling elements each from the compressive and tensile raceway. Since the balls are not in contact with each other, there is no collision noise. This reduces the noise in the recirculating system and the guidance systems run significantly more quietly.

Since the quad spacers are not connected chain elements, bending and tensile stresses are eliminated, particularly in the return area.

Under highly dynamic operating conditions or with ingress of contaminant particles into the guidance system, this design also averts the risk of fracture.

With its new linear recirculating ball bearing and guideway assembly KUVE..B KT, INA is providing a technologically pioneering product for low-noise applications. This linear guidance system possesses all the advantages of the highly successful full complement KUVE design and represents an optimum addition to the already extensive range of these units. In this way, the INA range now includes the ideal product for any application.

The KUVE..B KT is particularly suitable where the emphasis is on high dynamic characteristics and low noise.

Both new carriage versions can be used on the existing guideways.

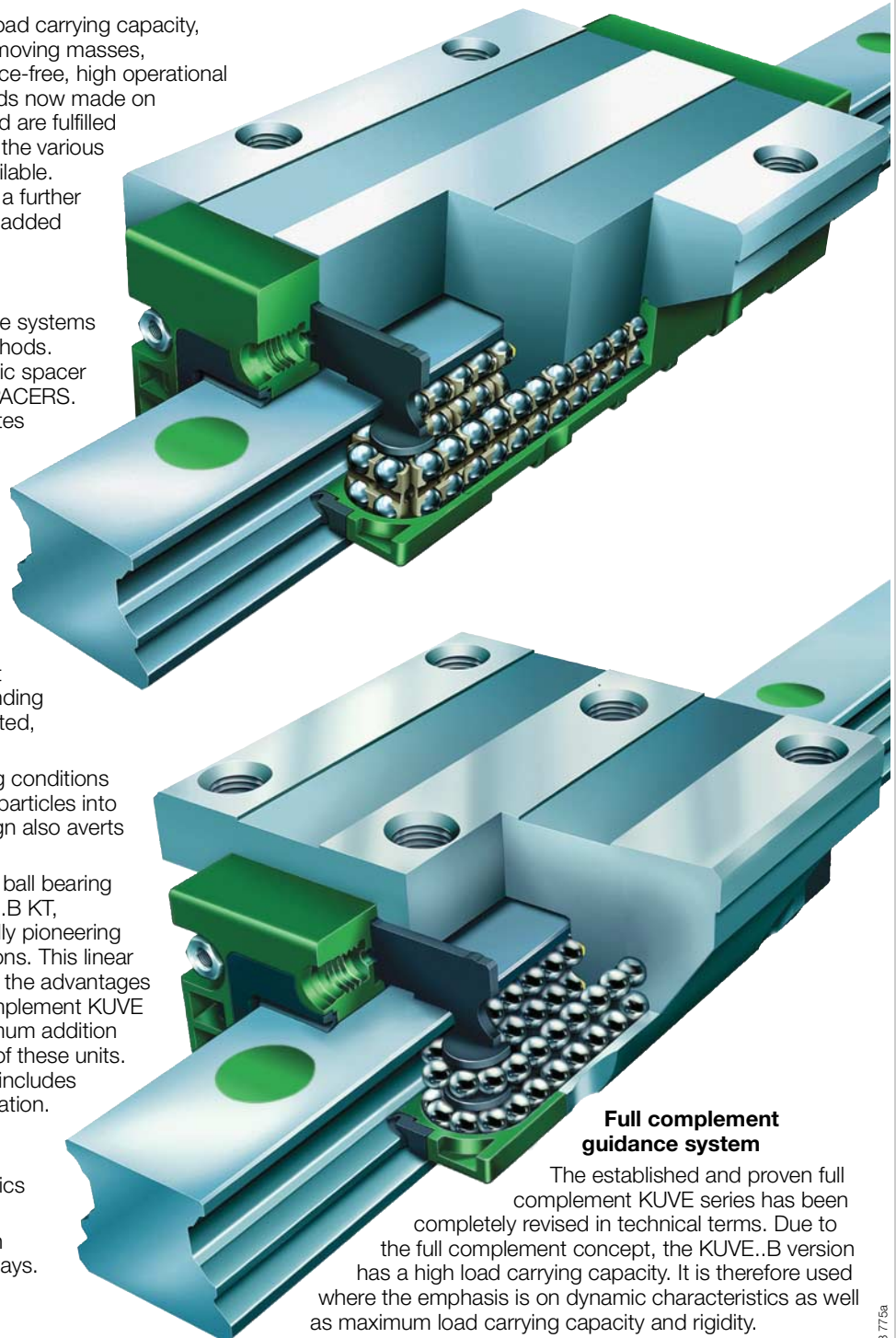





Full complement guidance system

The established and proven full complement KUVE series has been completely revised in technical terms. Due to the full complement concept, the KUVE..B version has a high load carrying capacity. It is therefore used where the emphasis is on dynamic characteristics as well as maximum load carrying capacity and rigidity.

173 775a

Four-row linear recirculating ball bearing and guideway assemblies

with quad spacers

	Page
 Preload.....	28
 Friction	28
 Accuracy	29
 Demands on the adjacent construction.....	32
 Ordering example and ordering designation	6



Features

Four-row linear recirculating ball bearing and guideway assemblies

- are complete units comprising:
 - at least one carriage KWVE..B KT
 - a guideway TKVD (U), TKVD..ZHP or TKVD..K with two locating edges in each case
 - plastic spacer elements to guide the rolling elements
 - integral elastic wipers and sealing strips on the end faces and longitudinal faces of the carriage
 - two-piece plastic closing plugs
- run with less noise than full complement designs
- can support loads from all directions – apart from the direction of motion – and moments about all axes
- are preloaded
 - the preload is determined by the carriage
- are lubricated via the lubrication nipple in the end piece (on the end face or from the side) with grease or oil
 - the end face lubrication nipple is included in the delivery
 - the lubrication nipple for relubrication from the side is available by agreement
- are based on a modular concept (see also *Interchangeability*, page 4)
 - guideways can be combined with all carriage types within one size
 - can be ordered separately as a carriage KWVE..B KT and guideway TKVD or as a unit KUVE..B KT. In a unit, one or more carriages can be mounted on a guideway
- are suitable for:
 - accelerations up to 150 m/s²
 - speeds up to 360 m/min¹⁾
 - operating temperatures from –10 °C to +100 °C
- can also be supplied with multi-piece guideways – see *Multi-piece guideways*, page 31
- are used in applications with:
 - long, unlimited stroke lengths
 - high dynamic characteristics
 - high running and positional accuracy
 - low friction
 - low noise levels.

¹⁾  For speeds >180 m/min, please consult INA.

Carriage

KWVE..B KT

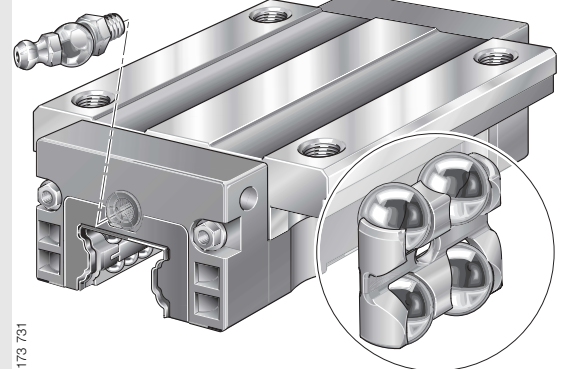

173 731

- saddle plate with hardened and precision ground rolling element raceways
 - balls are recirculated in enclosed channels with plastic return elements
- carriage sealed by elastic end wipers and sealing strips
- a lubrication nipple for the end face is included

Guideways

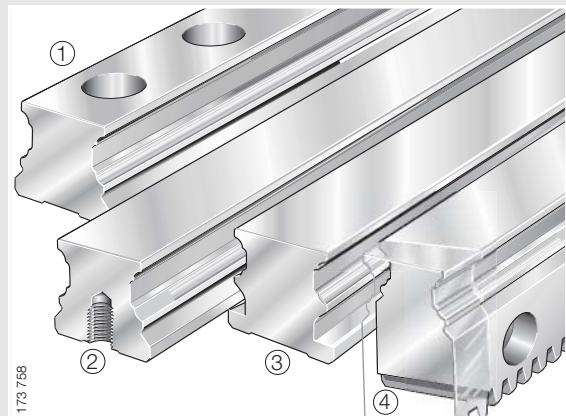

173 756

- hardened steel, all surfaces ground
 - precision ground raceways for rolling elements
- TKVD: located from above ①
- TKVD..U: located from below ②
- TKVD..K: for clamping lugs and clamping strips ③
- TKVD..ZHP: with helical teeth ④

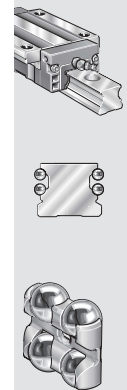

Four-row linear recirculating ball bearing and guideway assembly with quad spacers – scope of basic delivery

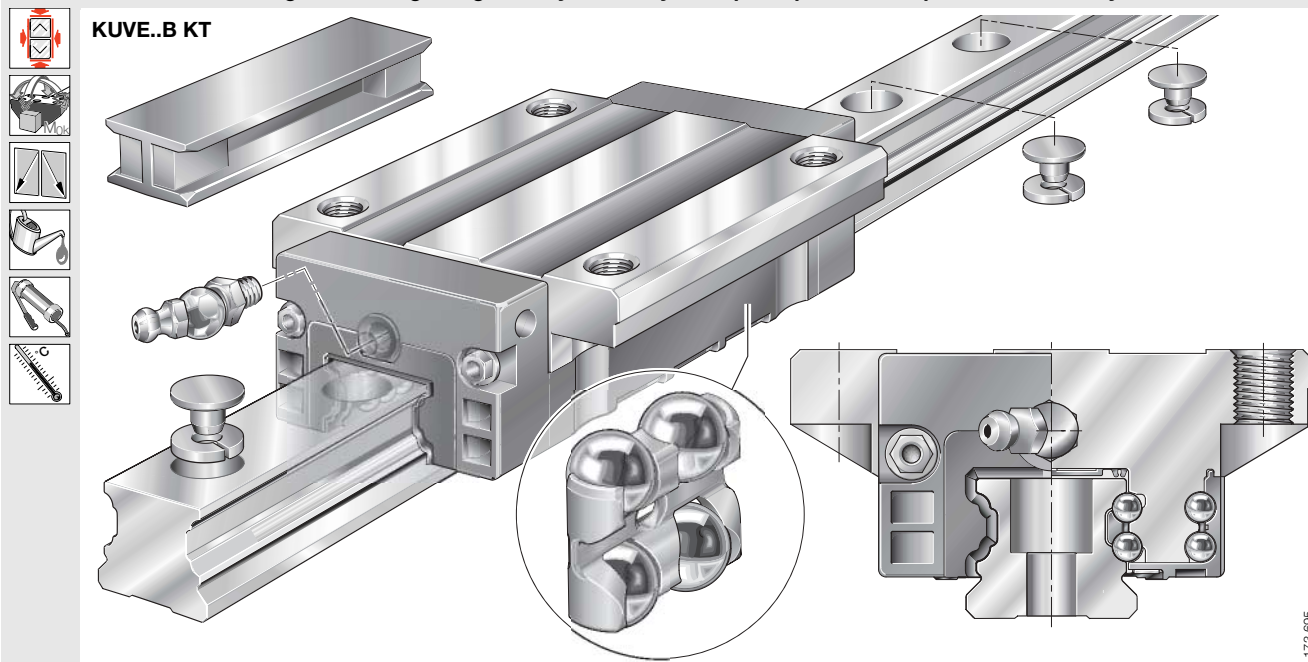

173 695

Standard accessories

MKVD

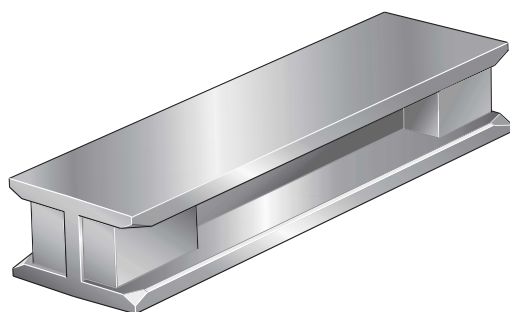

173 711

- plastic dummy guideways
 - prevent damage to the rolling element set while the carriage is separated from the guideway. The carriage is always pushed direct from the guideway onto the dummy guideway

KA..TN A

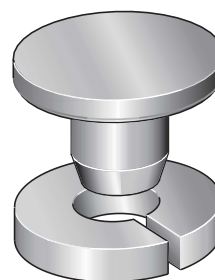

173 729

- two-piece plastic closing plugs
 - close off the counterbores of the guideway holes flush with the top surface of the guideway

Four-row linear recirculating ball bearing and guideway assemblies

with quad spacers

Design of carriages

The rows of balls run in a steel saddle plate with hardened and ground raceways at a contact angle of 45° in an O arrangement.

In order to prevent noise from recirculation, the rolling elements are guided in plastic spacer units called "quad spacers". The balls are recirculated in enclosed channels with plastic return elements.

Interchangeability

The guideways and carriages can be freely interchanged and combined with each other (see page 5).

This means:

- more economical stockholding
- simpler fitting
- quicker sourcing of replacement parts
- the option of achieving several preload classes on one guideway, since the preload class is determined by the carriage
- versatile design possibilities for KUBE guidance systems using standard elements.

Corrosion-resistant designs

KUBE..B KT is also available with the Corrotect® plating.

If carriages and guideways are ordered separately, the following applies:

- carriage and guideway with anti-corrosion protection:
 - suffix RRF.

If units are supplied preassembled, there are two variants:

- carriage and guideway with anti-corrosion protection
 - suffix RRF
- guideway only with anti-corrosion protection
 - suffix RRFT.

Lubricant reservoir, sealing

Due to the integral lubricant reservoir ①, the linear ball bearing and guideway assemblies have long relubrication intervals; depending on the application, they may even be maintenance-free.

Standard sealing strips ② as well as additional sealing strips (optional) ③ ensure effective sealing.

These sealing elements protect the rolling element system from contamination even under demanding environmental conditions.

Contact angle, quad spacers

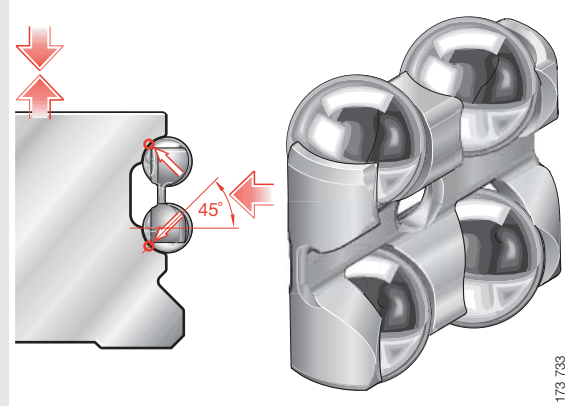

- quad spacers (plastic spacer elements)
- contact angles of the four rows of balls
- rows of balls in two point contact with raceways

173 733

Lubricant reservoir, sealing

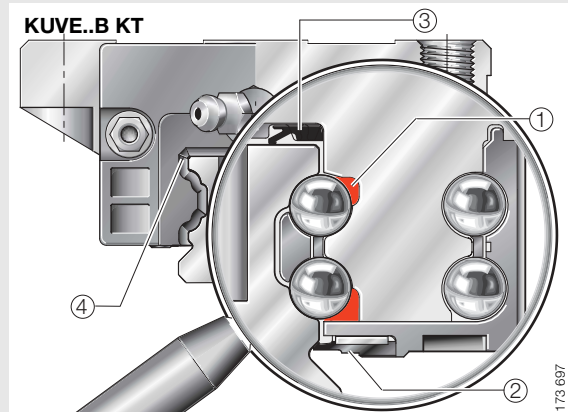

- integral lubricant pockets with grease reservoir ①
- standard sealing strip ②
- optional sealing strip ③
- elastic wipers on end faces ④

173 697

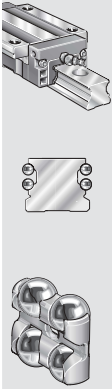

KWVE..B KT S

KWVE..B KT SL

KWVE..B KT H

KWVE..B KT HL

KWVE..B KT L

KWVE..B KT

TKVD

TKVD..U

TKVD..K

TKVD..ZHP

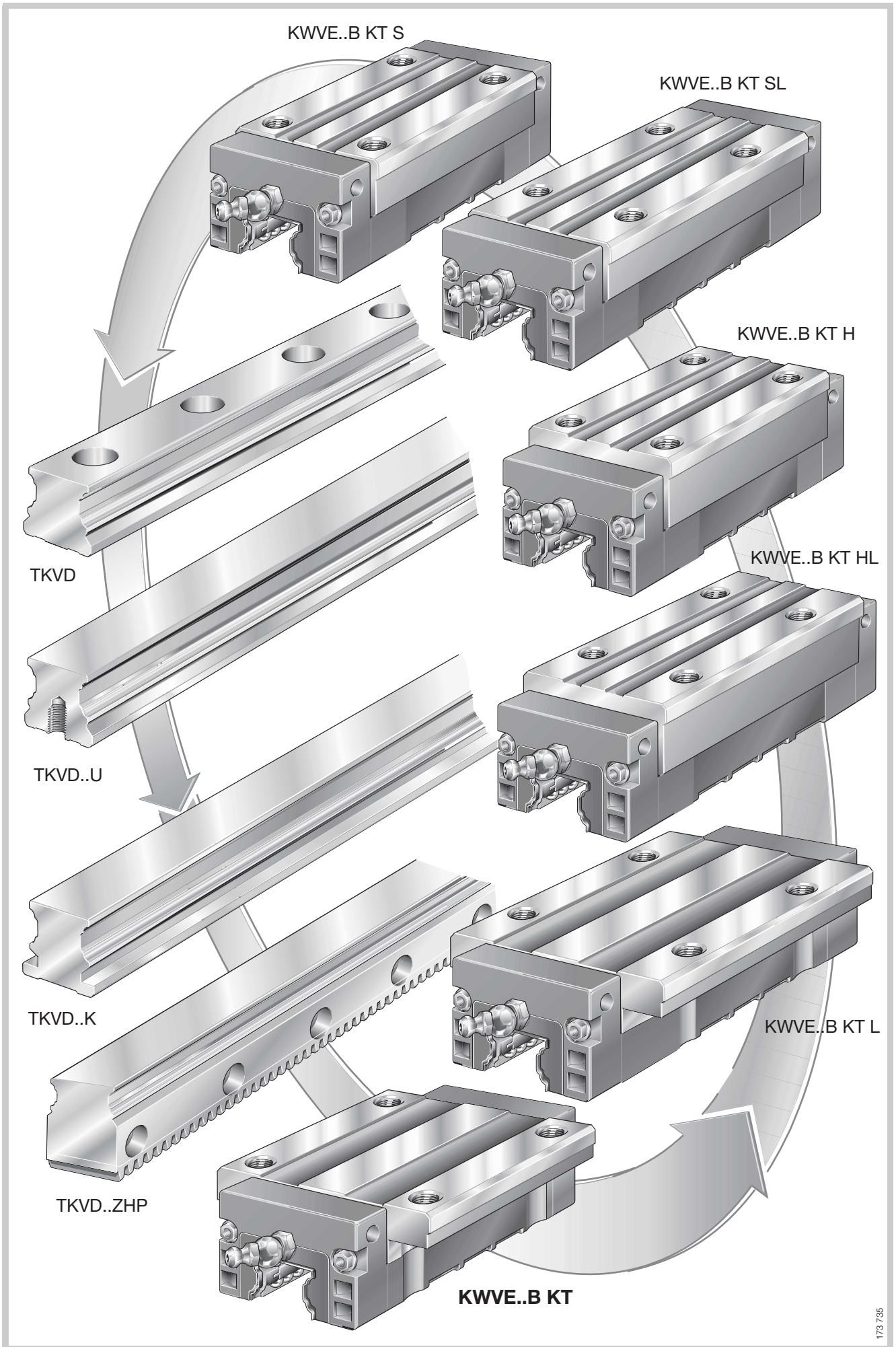

Four-row linear recirculating ball bearing and guideway assemblies

with quad spacers



Ordering example and ordering designation

Ordering designation:

1×KUBE 25 B KT W2 G3 V2 RRFT/1510-50/20 (Figure 1).

Ordering example 1

Linear recirculating ball bearing and guideway assembly KUBE..B KT, asymmetrical hole pattern

Four-row ball bearing and guideway assembly	KUBE
Size	25
Version with plastic spacer elements	B KT
Number of carriages per unit	W2
Accuracy class	G3
Carriage preload	V2
Guideway with Corrotect® plating	RRFT
Guideway length	1510 mm
- a _L	50 mm
- a _R	20 mm

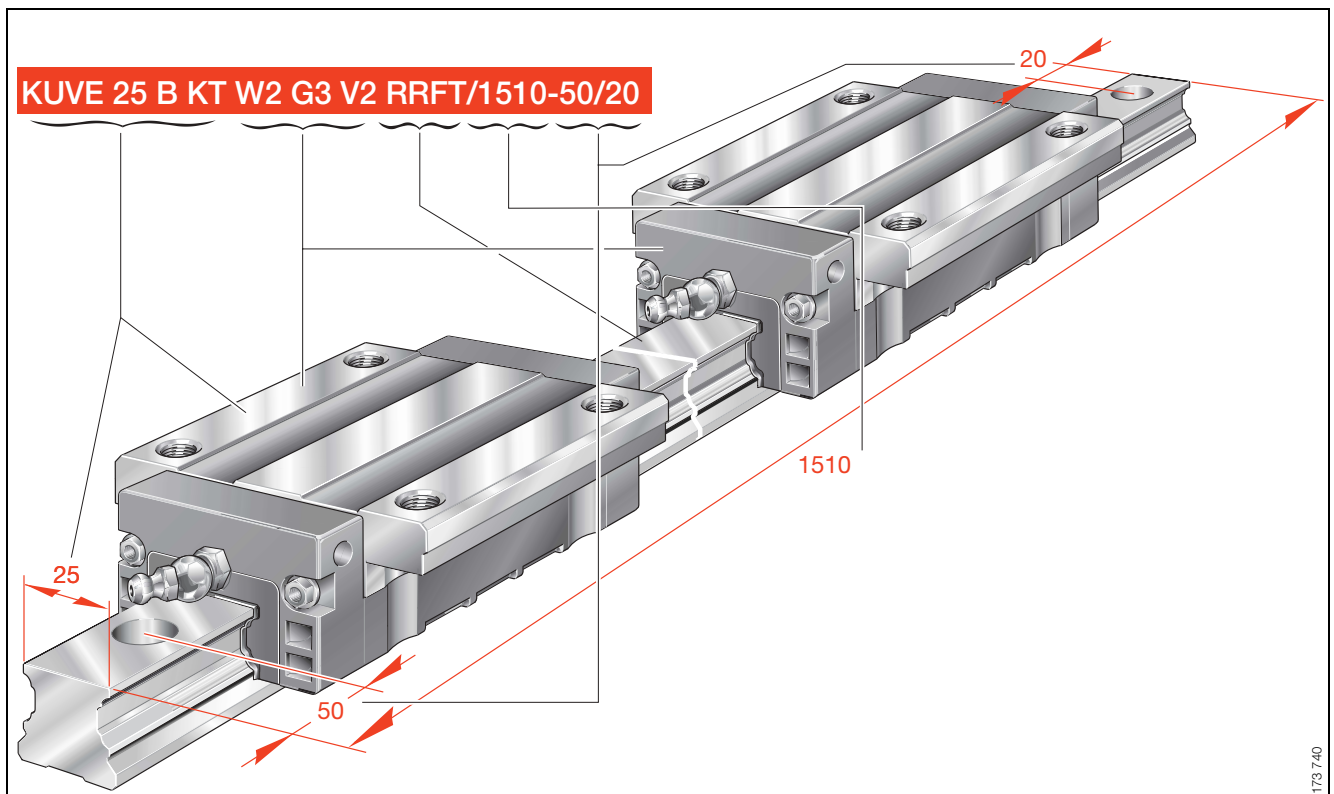
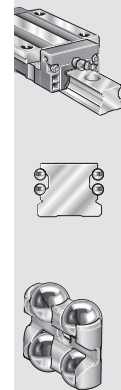

Figure 1 · Ordering example, ordering designation



Ordering example 2

Linear recirculating ball bearing and guideway assembly KUVE..B KT, carriage and guideway separate, symmetrical hole pattern

Carriage

Carriage	KWVE
Size	25
Version with plastic spacer elements	B KT
Carriage variant	L
Accuracy class	G3
Carriage preload	V2

Guideway

Guideway for carriage	TKVD
Size	25
Guideway length	1570 mm
- a _L	35 mm
- a _R	35 mm

Ordering designation:

1×TKVD 25/1570-35/35 (Figure 2).

Ordering designation:

2×KWVE 25 B KT L G3 V2 (Figure 2).

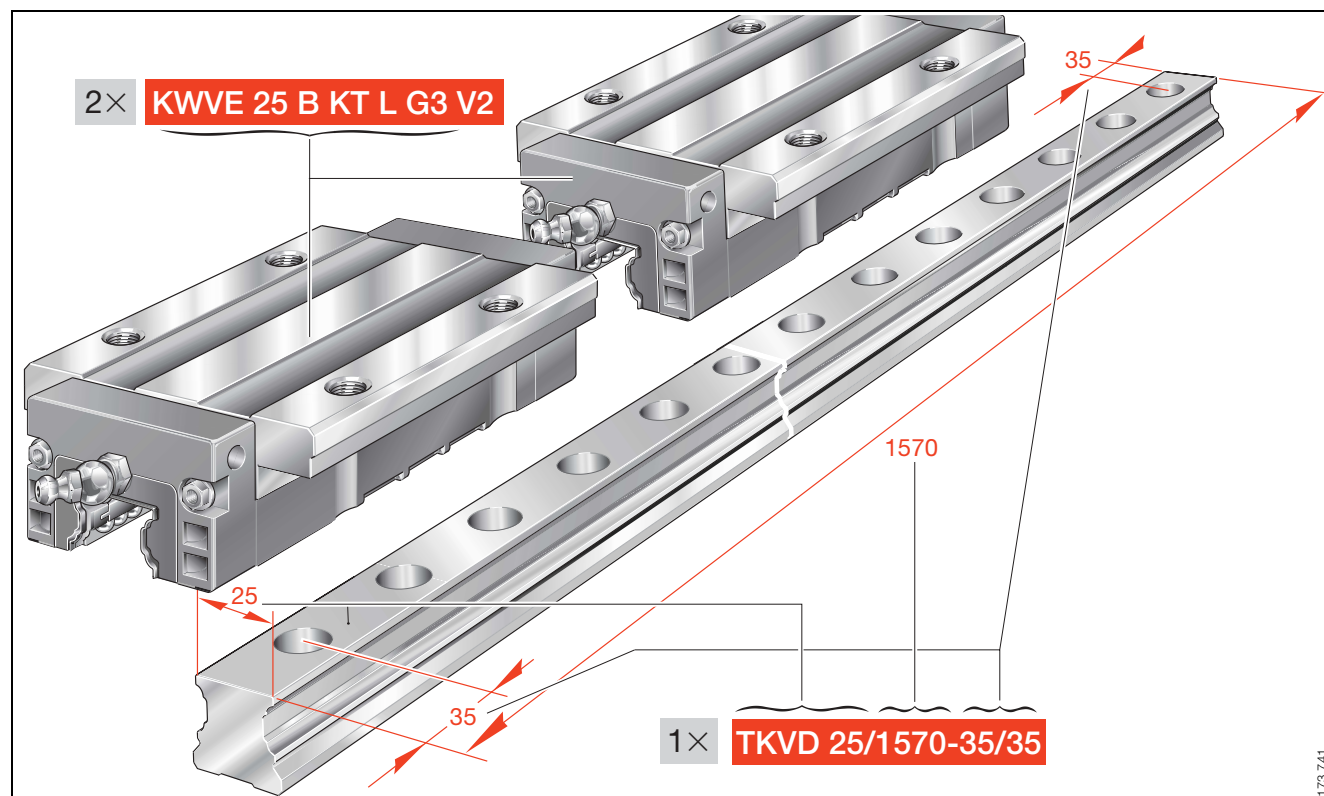
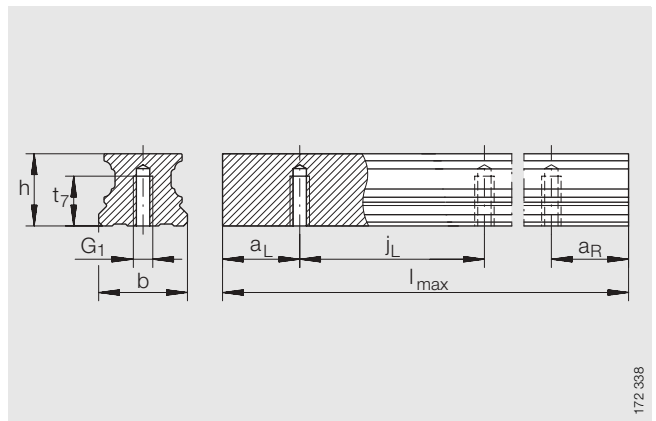

Figure 2 · Ordering example, ordering designation

Four-row linear recirculating ball bearing and guideway assemblies

with quad spacers

Series KUVE..B KT
KUVE..B KT L



TKVD..U

172 338

Dimension table · Dimensions in mm

Unit Designation	Carriage		Guideway			Dimensions			
	Designation	Mass m ≈kg	Designation	Mass m ≈kg/m	Closing plug K ₂	l _{max} ¹⁾	H	B	L
KUVE 15 B KT	KWVE 15 B KT	0,17	TKVD 15 B (U) ⁷⁾	1,44	KA 07 TN A	1200	24	47	59,6
KUVE 15 B KT L	KWVE 15 B KT L	0,21							73
KUVE 20 B KT	KWVE 20 B KT	0,38	TKVD 20 (U)	2,2	KA 10 TN A	1980	30	63	69,8
KUVE 20 B KT L	KWVE 20 B KT L	0,5							87,3
KUVE 25 B KT	KWVE 25 B KT	0,5	TKVD 25 (U)	2,7	KA 11 TN A	1980	36	70	82,1
KUVE 25 B KT L	KWVE 25 B KT L	0,62							107,9

- 1) Maximum length of single-piece guideways; longer guideways are supplied in several sections and are marked accordingly. Maximum single-piece guideway length of 6 m by agreement.
- 2) a_L and a_R are dependent on the guideway length, *Calculation*, page 31.
- 3) If there is a possibility of settling, the fixing screws should be secured against rotation.
- 4) For information on fixing screws see *INA Catalogue "605", Fixing screws*.
- 5) Calculation of basic load ratings in accordance with DIN 636. Based on practical experience, it may be possible to increase the basic dynamic load rating.
- 6) Lubrication nipple with tapered head to DIN 71412-B M6, except for KUVE 20 B KT..: to DIN 71412-B M5 and KUVE 15 B KT..: to DIN 3405 M3.
- 7) The new carriages cannot be used on the existing guideways TKVD 15 (U).

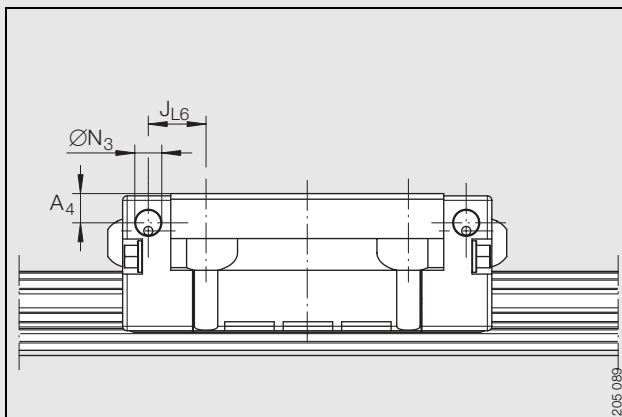

Lateral lubrication connector

Dimensioning of lateral lubrication connector

Designation	ØN ₃	A ₄	JL ₆
KUVE 15 B KT	2,7	3,2	9,1
KUVE 15 B KT L	2,7	3,2	15,8
KUVE 20 B KT	4,7	4,5	9,5
KUVE 20 B KT L	4,7	4,5	18,3
KUVE 25 B KT	5,6	6,5	12,9
KUVE 25 B KT L	5,6	6,5	25,8

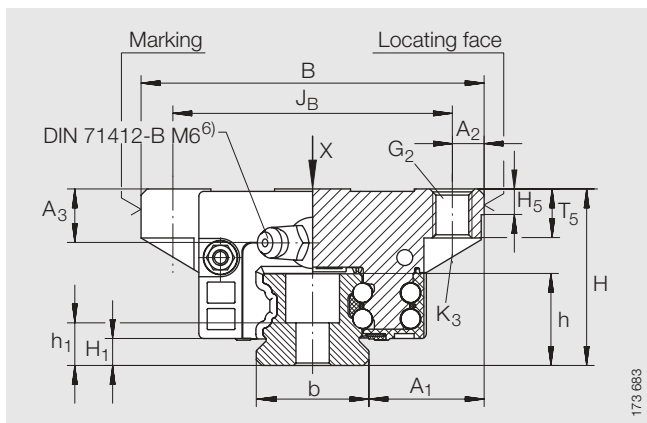

KUVE..B KT (L)

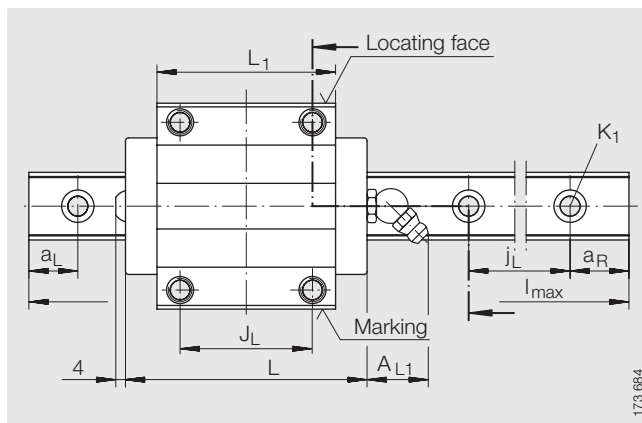

KUVE..B KT (L) · View X (rotated 90°)

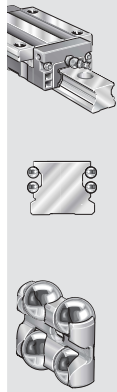

Mounting dimensions																	Fixing screws ³⁾⁴⁾			
A ₁	J _B	b -0,005 -0,03	A ₂	L ₁	J _L	j _L	a _L /a _R ²⁾		A _{L1}	H ₁	H ₅	A ₃	T ₅	t ₇	h	h ₁	G ₁	G ₂	K ₁	K ₃
							min.	max.												
16	38	15	4,5	39,8	30	60	20	53	6,7	4,5	4,75	4	7	8	15	8,15	M5	M5	M4	M4
				53,2																
21,5	53	20	5	50,4	40	60	20	53	19	4,5	5,25	8	7,5	10	17	9,1	M6	M6	M5	M5
				67,9																
23,5	57	23	6,5	60,7	45	60	20	53	19	5,5	5,25	11	10	12	18,7	8,7	M6	M8	M6	M6
				86,5																

Load carrying capacity (for definition of basic load ratings, see INA Catalogue "605") ⁵⁾					
Unit Designation	Basic load ratings		Moment ratings		
	C N	C ₀ N	M _{0x} Nm	M _{0y} Nm	M _{0z} Nm
KUVE 15 B KT	6 100	11 400	105	74	53
KUVE 15 B KT L	7 500	15 500	162	148	105
KUVE 20 B KT	11 800	23 000	253	130	127
KUVE 20 B KT L	14 400	30 500	335	225	225
KUVE 25 B KT	16 200	32 000	370	210	200
KUVE 25 B KT L	21 100	47 000	535	430	410

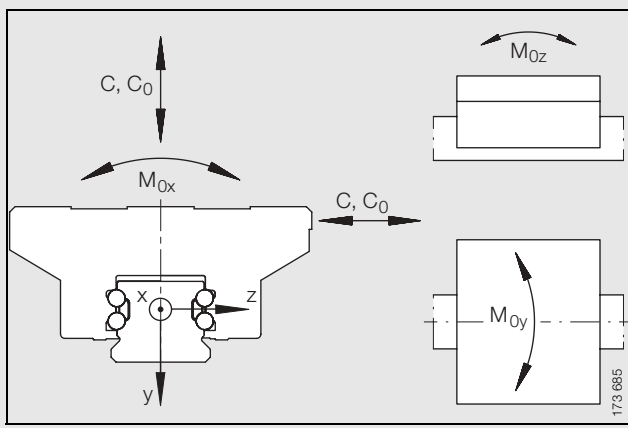

Load directions

Four-row linear recirculating ball bearing and guideway assemblies

with quad spacers

Series KUVE..B KT S
 KUVE..B KT H
 KUVE..B KT SL
 KUVE..B KT HL

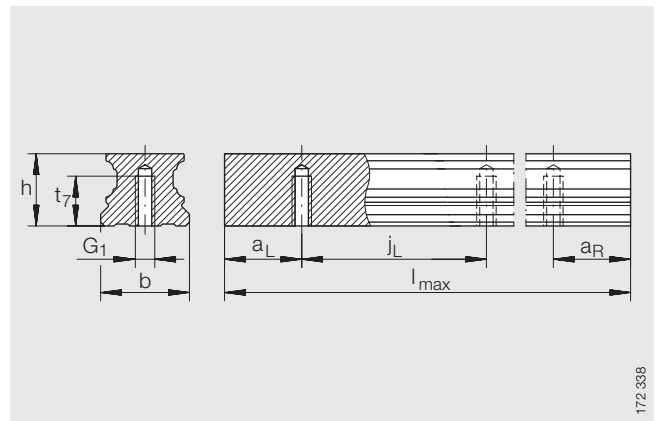

TKVD..U

172 338

Dimension table · Dimensions in mm

Unit Designation	Carriage		Guideway			Dimensions			
	Designation	Mass m ≈ kg	Designation	Mass m ≈ kg/m	Closing plug K ₂	l _{max} ¹⁾	H	B	L
KUVE 15 B KT S	KWVE 15 B KT S	0,15	TKVD 15 B (U) ⁷⁾	1,44	KA 07 TN A	1200	24	34	59,6
KUVE 15 B KT H	KWVE 15 B KT H	0,18					28		
KUVE 15 B KT SL	KWVE 15 B KT SL	0,18					24		
KUVE 15 B KT HL	KWVE 15 B KT HL	0,21					28		
KUVE 20 B KT S	KWVE 20 B KT S	0,3	TKVD 20 (U)	2,2	KA 10 TN A	1980	30	44	69,8
KUVE 20 B KT SL	KWVE 20 B KT SL	0,4					87,3		
KUVE 25 B KT S	KWVE 25 B KT S	0,57	TKVD 25 (U)	2,7	KA 11 TN A	1980	36	48	82,1
KUVE 25 B KT H	KWVE 25 B KT H	0,61					40		
KUVE 25 B KT SL	KWVE 25 B KT SL	0,79					36		
KUVE 25 B KT HL	KWVE 25 B KT HL	0,86					40		107,9

- 1) Maximum length of single-piece guideways; longer guideways are supplied in several sections and are marked accordingly. Maximum single-piece guideway length of 6 m by agreement.
- 2) a_L and a_R are dependent on the guideway length, *Calculation*, page 31.
- 3) If there is a possibility of settling, the fixing screws should be secured against rotation.
- 4) For information on fixing screws see *INA Catalogue "605", Fixing screws*.
- 5) Calculation of basic load ratings in accordance with DIN 636. Based on practical experience, it may be possible to increase the basic dynamic load rating.
- 6) Lubrication nipple with tapered head to DIN 71 412-B M6, except for KUVE 20 B KT..: to DIN 71 412-B M5 and KUVE 15 B KT..: to DIN 3 405 M3.
- 7) The new carriages cannot be used on the existing guideways TKVD 15 (U).

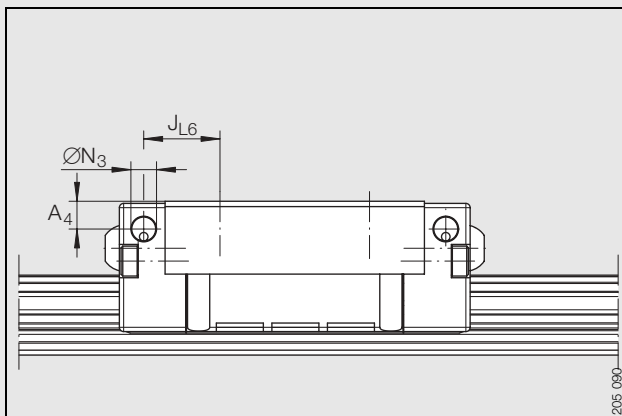

Lateral lubrication connector

Dimensioning of lateral lubrication connector

Designation	ØN ₃	A ₄	JL ₆
KUVE 15 B KT S	2,7	3,2	11,1
KUVE 15 B KT H	2,7	7,2	11,1
KUVE 15 B KT SL	2,7	3,2	17,8
KUVE 15 B KT HL	2,7	7,2	17,8
KUVE 20 B KT S	4,7	4,5	11,5
KUVE 20 B KT SL	4,7	4,5	13,3
KUVE 25 B KT S	5,6	6,5	17,9
KUVE 25 B KT H	5,6	10,5	17,9
KUVE 25 B KT SL	5,6	6,5	23,3
KUVE 25 B KT HL	5,6	10,5	23,3

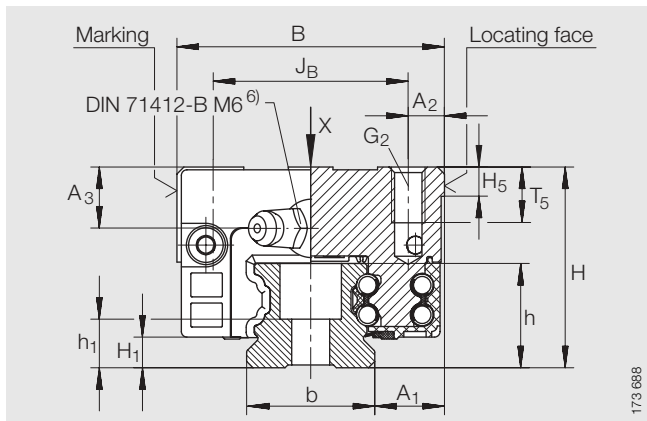
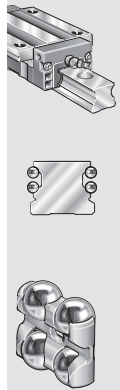

KUVE..B KT S (H, SL, HL)

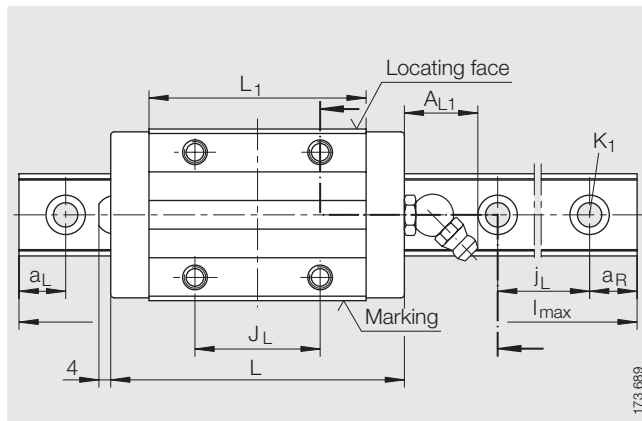

KUVE..B KT S (H, SL, HL) · View X (rotated 90°)

Mounting dimensions																Fixing screws ³⁾⁴⁾				
A ₁	J _B	b -0,005 -0,03	A ₂	L ₁	J _L	j _L	a _L /a _R ²⁾		A _{L1}	H ₁	H ₅	A ₃	T ₅	t ₇	h	h ₁	G ₁	G ₂	K ₁	K ₃
							min.	max.												
9,5	26	15	4	39,8	26	60	20	53	6,7	4,5	4,75	4	7	8	15	8,15	M5	M5	M4	M4
				53,2								8								
				4																
12	32	20	6	50,4	36	60	20	53	19	4,5	5,25	8	7,5	10	17	9,1	M6	M5	M5	M5
				67,9	50															
12,5	35	23	6,5	60,7	35	60	20	53	19	5,1	5,25	11	10	12	18,7	8,7	M6	M8	M6	M6
				15																
				11																
				15																



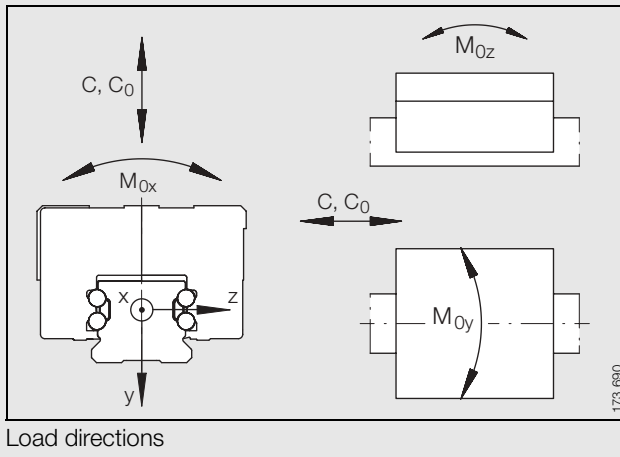

Load carrying capacity (for definition of basic load ratings, see INA Catalogue "605") ⁵⁾					
Unit Designation	Basic load ratings		Moment ratings		
	C N	C ₀ N	M _{0x} Nm	M _{0y} Nm	M _{0z} Nm
KUVE 15 B KT S	6 100	11 400	105	82	53
KUVE 15 B KT H	6 100	11 400	105	82	53
KUVE 15 B KT SL	7 500	15 500	162	148	105
KUVE 15 B KT HL	7 500	15 500	162	148	105
KUVE 20 B KT S	11 800	23 000	253	130	127
KUVE 20 B KT SL	14 400	30 500	335	225	225
KUVE 25 B KT S	16 200	32 000	370	210	200
KUVE 25 B KT H	16 200	32 000	370	210	200
KUVE 25 B KT SL	21 100	47 000	535	430	410
KUVE 25 B KT HL	21 100	47 000	535	430	410



Load directions

Four-row linear recirculating ball bearing and guideway assemblies

full complement

	Page
 Preload.....	28
 Friction	28
 Accuracy	29
 Demands on the adjacent construction.....	32
 Ordering example and ordering designation	16



Features

Four-row linear recirculating ball bearing and guideway assemblies

- are complete units comprising:
 - at least one carriage KWVE..B
 - a guideway TKVD (U), TKVD..ZHP or TKVD..K with two locating edges in each case
 - integral elastic wipers and sealing strips on the end faces and longitudinal faces of the carriage
 - two-piece plastic closing plugs
 - have a full complement ball set
- can support loads from all directions – apart from the direction of motion – and moments about all axes
- are preloaded
 - the preload is determined by the carriage
- are lubricated via the lubrication nipple in the end piece (on the end face or from the side) with grease or oil
 - the end face lubrication nipple is included in the delivery
 - the lubrication nipple for relubrication from the side is available by agreement
- are based on a modular concept (see also *Interchangeability*, page 14)
 - guideways can be combined with all carriage types within one size
 - can be ordered separately as a carriage KWVE..B and guideway TKVD or as a unit KUVE..B. In a unit, one or more carriages can be mounted on a guideway
- are suitable for:
 - accelerations up to 150 m/s²
 - speeds up to 360 m/min
 - operating temperatures from –10 °C to +100 °C
- can also be supplied with multi-piece guideways – see *Multi-piece guideways*, page 31
- are used in applications with:
 - long, unlimited stroke lengths
 - high loads
 - high running and positional accuracy
 - low friction
 - high rigidity.

Carriage

KWVE..B

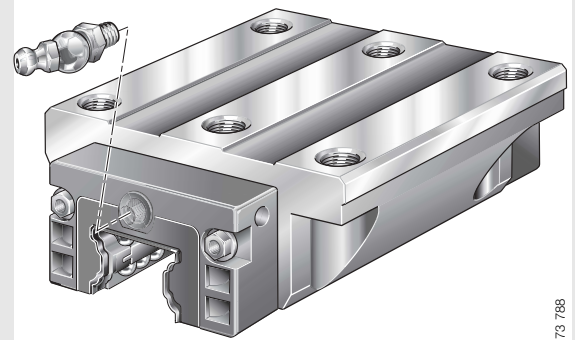

- saddle plate with hardened and precision ground rolling element raceways
 - balls are recirculated in enclosed channels with plastic return elements
- carriage sealed by elastic end wipers and sealing strips
- a lubrication nipple for the end face is included

Guideways

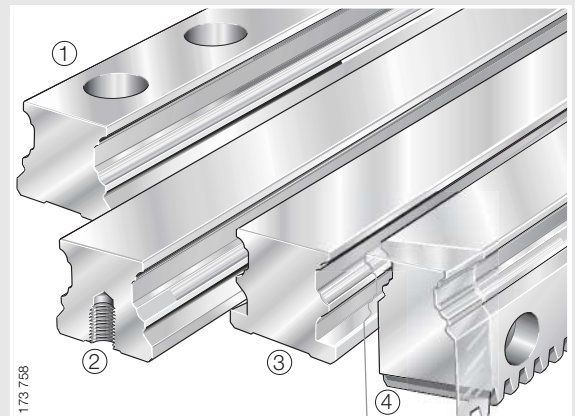

- hardened steel, all surfaces ground
 - precision ground raceways for rolling elements
- TKVD: located from above ①
- TKVD..U: located from below ②
- TKVD..K: for clamping lugs and clamping strips ③
- TKVD..ZHP: with helical teeth ④

Four-row linear recirculating ball bearing and guideway assembly, full complement – scope of basic delivery

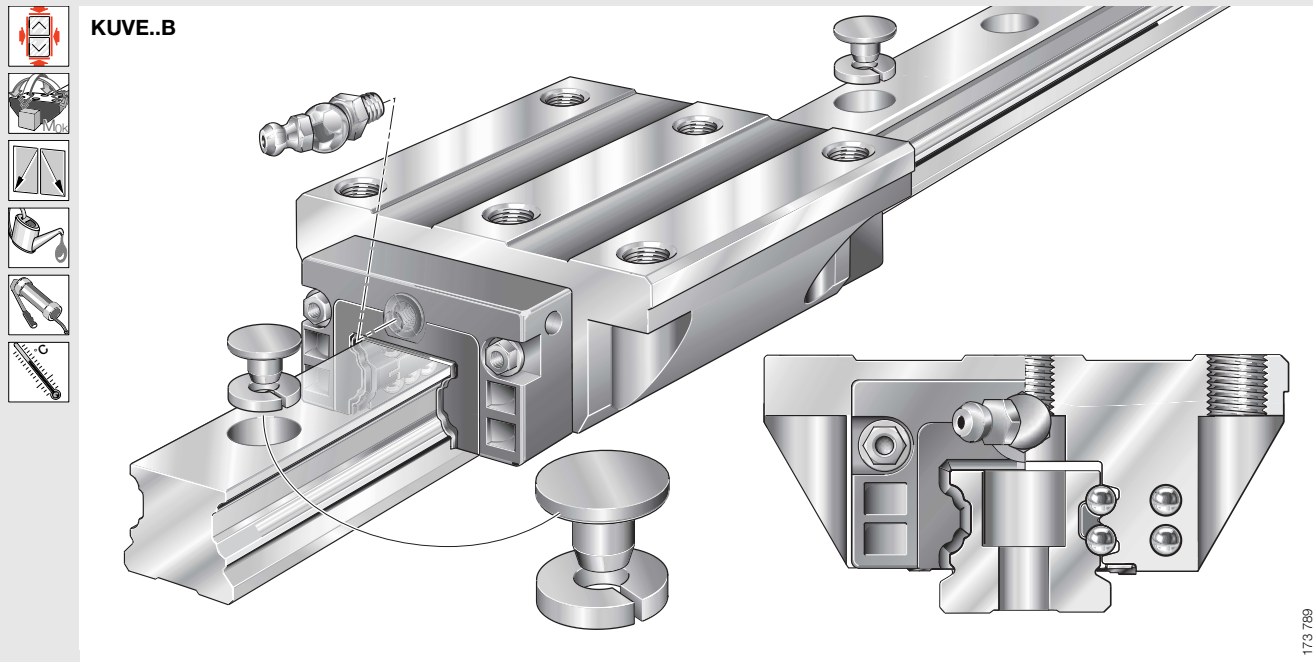

KUVE..B

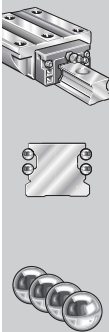

Standard accessories

MKVD

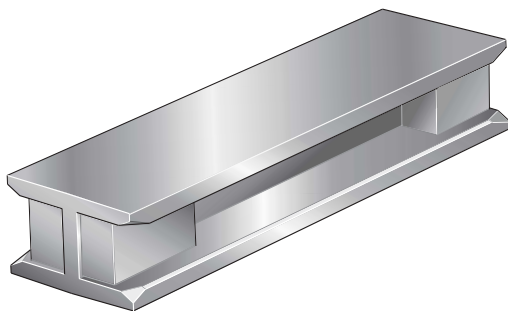

173 711

- plastic dummy guideways
 - prevent damage to the rolling element set while the carriage is separated from the guideway. The carriage is always pushed direct from the guideway onto the dummy guideway

KA..TN A

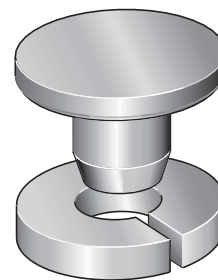

173 729

- two-piece plastic closing plugs
 - close off the counterbores of the guideway holes flush with the top surface of the guideway

Four-row linear recirculating ball bearing and guideway assemblies

full complement

Design of carriages

The rows of balls run in a steel saddle plate with hardened and ground raceways at a contact angle of 45° in an O arrangement.

The full complement ball set is recirculated through channels in the steel saddle plate.

Interchangeability

The carriages and guideways can be freely interchanged and combined with each other.

This means:

- more economical stockholding
- simpler fitting
- quicker sourcing of replacement parts
- the option of achieving several preload classes on one guideway, since the preload class is determined by the carriage
- versatile design possibilities for KUBE guidance systems using standard elements.

Corrosion-resistant designs

KUBE..B is also available with the Corrotect® plating.

If carriages and guideways are ordered separately, the following applies:

- carriage and guideway with anti-corrosion protection:
– suffix RRF.

If units are supplied preassembled, there are two variants:

- carriage and guideway with anti-corrosion protection
– suffix RRF
- guideway only with anti-corrosion protection
– suffix RRFT.

Lubricant reservoir, sealing

Due to the integral lubricant reservoir ①, the linear ball bearing and guideway assemblies have long relubrication intervals; depending on the application, they may even be maintenance-free.

Standard sealing strips ② as well as additional sealing strips (optional) ③ ensure effective sealing.

These sealing elements protect the rolling element system from contamination even under demanding environmental conditions.

Contact angle

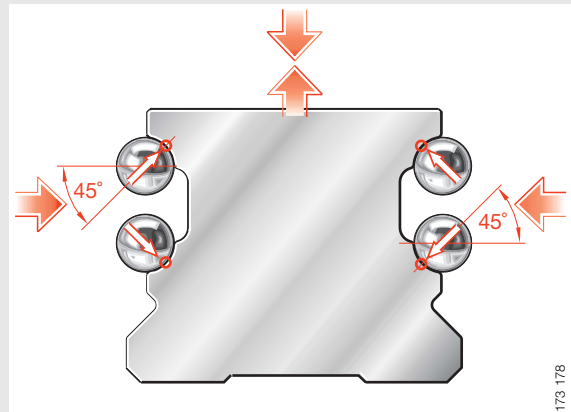

- contact angles of the four rows of balls
- rows of balls in two point contact with raceways

173 178

Lubricant reservoir, sealing

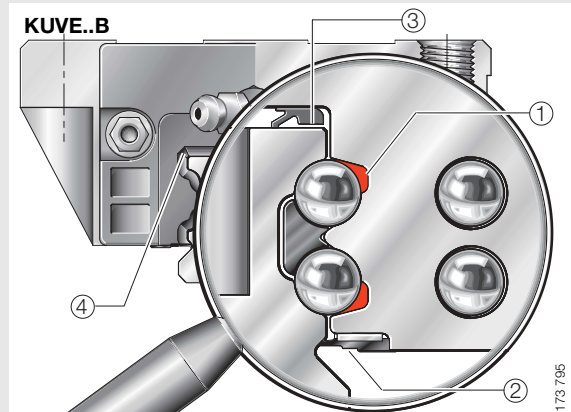

- integral lubricant pockets with grease reservoir ①
- standard sealing strip ②
- optional sealing strip ③
- elastic wipers on end faces ④

173 795

KWVE..B SNL

KWVE..B SN

KWVE..B S

KWVE..B EC

KWVE..B SL

KWVE..B ESC

KWVE..B H

KUVE..B

TKVD

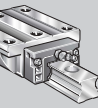

TKVD..U

KWVE..B HL

TKVD..K

TKVD..ZHP

KWVE..B
KWVE..B N

KWVE..B L
KWVE..B NL

205 091

Four-row linear recirculating ball bearing and guideway assemblies

full complement



Ordering example and ordering designation

Ordering designation:

1×KUVE 25 B W2 G3 V2 RRFT/1510-50/20 (Figure 1).

Ordering example 1

Linear ball bearing and guideway assembly KUVE..B,
asymmetrical hole pattern

Four-row ball bearing and guideway assembly	KUVE
Size	25
Version with full complement ball set	B
Number of carriages per unit	W2
Accuracy class	G3
Carriage preload	V2
Guideway with Corrotect® plating	RRFT
Guideway length	1510 mm
- a _L	50 mm
- a _R	20 mm

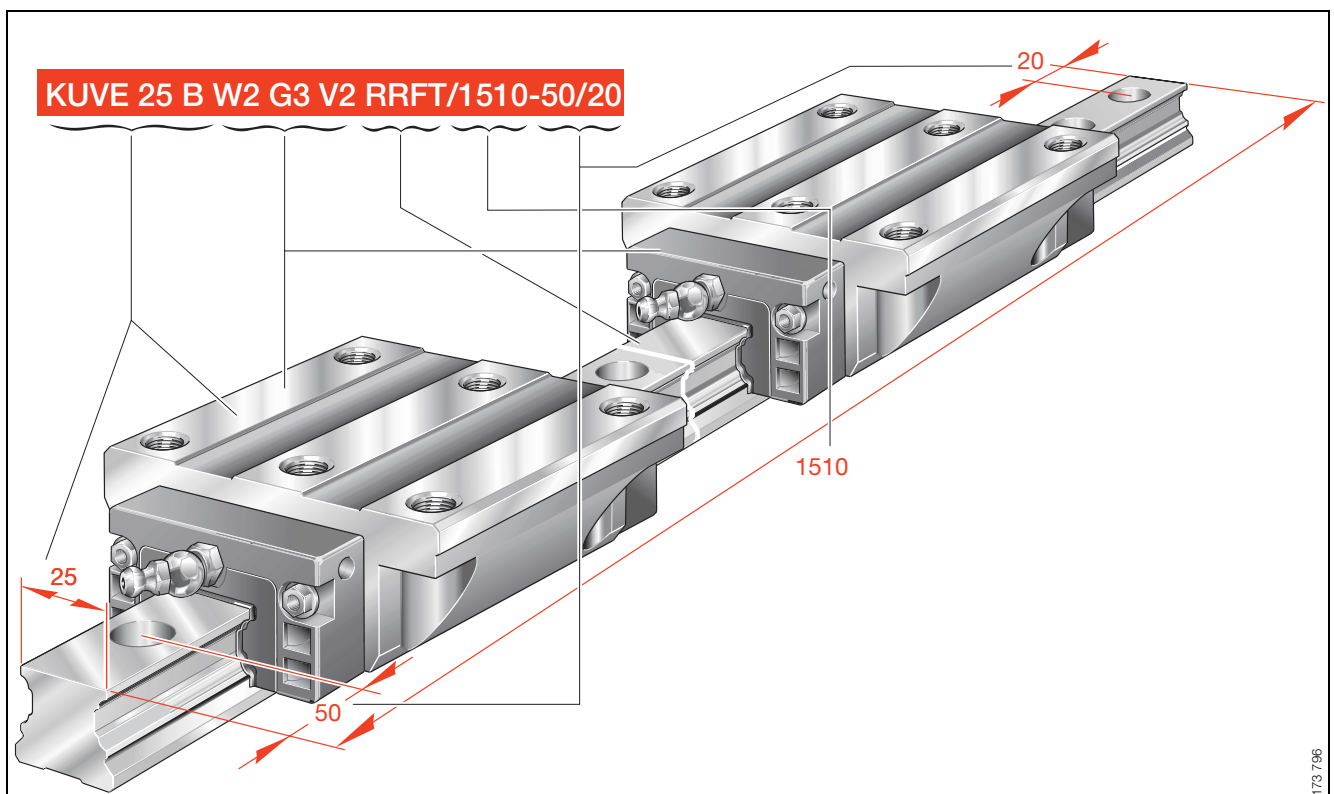

Figure 1 · Ordering example, ordering designation

Ordering example 2

Linear recirculating ball bearing and guideway assembly KUVE..B, carriage and guideway separate, symmetrical hole pattern

Carriage

Carriage

Size

Version with full complement ball set

Carriage variant

Accuracy class

Carriage preload

KWVE

25

B

L

G3

V2

Guideway

Guideway for carriage

Size

Guideway length

- a_L

- a_R

TKVD

25

1570 mm

35 mm

35 mm

Ordering designation:

1×TKVD 25/1570-35/35 (Figure 2).

Ordering designation:

2×KWVE 25 B L G3 V2 (Figure 2).

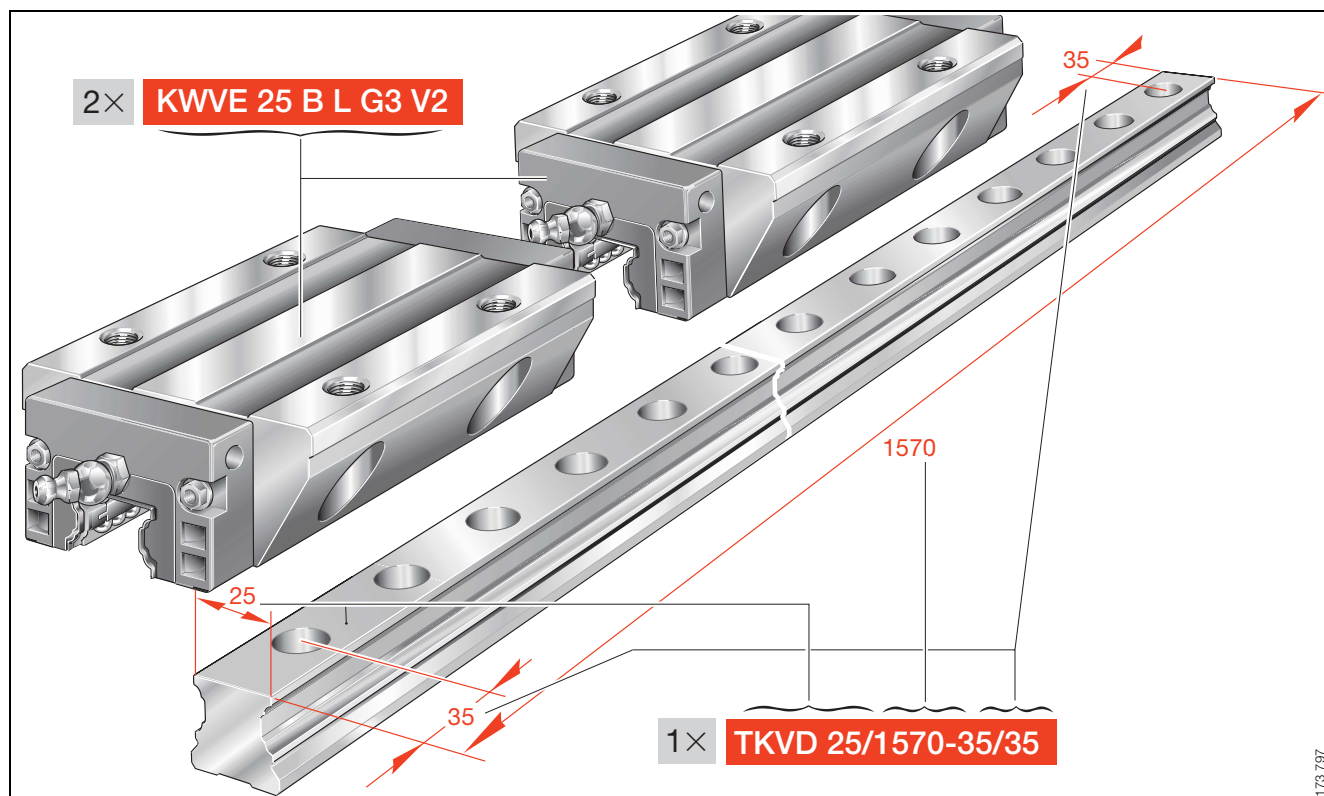
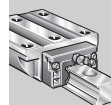

Figure 2 · Ordering example, ordering designation

KUVE..B



Four-row linear recirculating ball bearing and guideway assemblies

full complement

Series KUVE..B
 KUVE..B L
 KUVE..B N
 KUVE..B NL

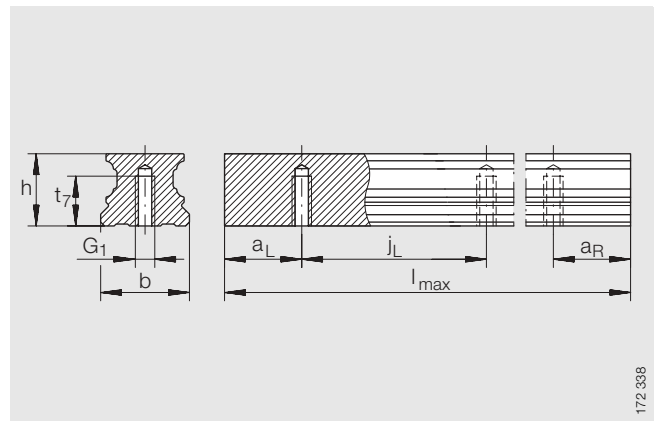

TKVD..U

Dimension table · Dimensions in mm

Unit Designation	Carriage		Guideway			Dimensions				Mounting dimensions			
	Designation	Mass m ≈kg	Designation	Mass m ≈kg/m	Closing plug K ₂	l _{max} ¹⁾	H	B	L	A ₁	J _B	b -0,005 -0,03	A ₂
KUVE 15 B	KWVE 15 B	0,25	TKVD 15 B (U) ⁷⁾	1,44	KA 07 TN A	1200	24	47	59,6	16	38	15	4,5
KUVE 20 B	KWVE 20 B	0,58	TKVD 20 (U)	2,2	KA 10 TN A	1980	30	63	69,8	21,5	53	20	5
KUVE 20 B L	KWVE 20 B L	0,8					27		87,3				
KUVE 20 B N	KWVE 20 B N	0,47					69,8						
KUVE 20 B NL	KWVE 20 B NL	0,65					87,3						
KUVE 25 B	KWVE 25 B	0,71	TKVD 25 (U)	2,7	KA 11 TN A	1980	36	70	81,7	23,5	57	23	6,5
KUVE 25 B L	KWVE 25 B L	1					31		107,5				
KUVE 25 B N	KWVE 25 B N	0,57					81,7						
KUVE 25 B NL	KWVE 25 B NL	0,8					107,5						

- 1) Maximum length of single-piece guideways; longer guideways are supplied in several sections and are marked accordingly. Maximum single-piece guideway length of 6 m by agreement.
- 2) a_L and a_R are dependent on the guideway length, *Calculation*, page 31.
- 3) If there is a possibility of settling, the fixing screws should be secured against rotation.
- 4) For information on fixing screws see *INA Catalogue "605", Fixing screws*.
- 5) Calculation of basic load ratings in accordance with DIN 636. Based on practical experience, it may be possible to increase the basic dynamic load rating.
- 6) Lubrication nipple with tapered head to DIN 71 412-B M6, except for KUVE 20 B..: to DIN 71 412-B M5 and KUVE 15 B..: to DIN 3 405 M3.
- 7) The new carriages cannot be used on the existing guideways TKVD 15 (U).

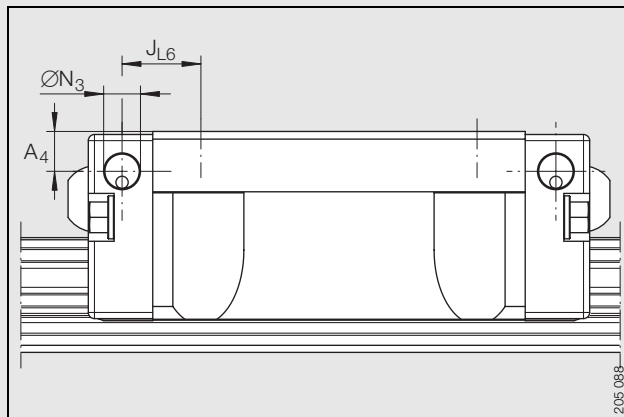

Lateral lubrication connector

Dimensioning of lateral lubrication connector

Designation	ØN ₃	A ₄	JL ₆
KUVE 15 B	2,7	3,2	9,1
KUVE 20 B	4,7	4,6	9,4
KUVE 20 B L	4,7	4,6	18,2
KUVE 20 B N	2,7	3,3	9,4
KUVE 20 B NL	2,7	3,3	18,2
KUVE 25 B	5,6	6,5	12,9
KUVE 25 B L	5,6	6,5	25,8
KUVE 25 B N	2,7	4	12,1
KUVE 25 B NL	2,7	4	25

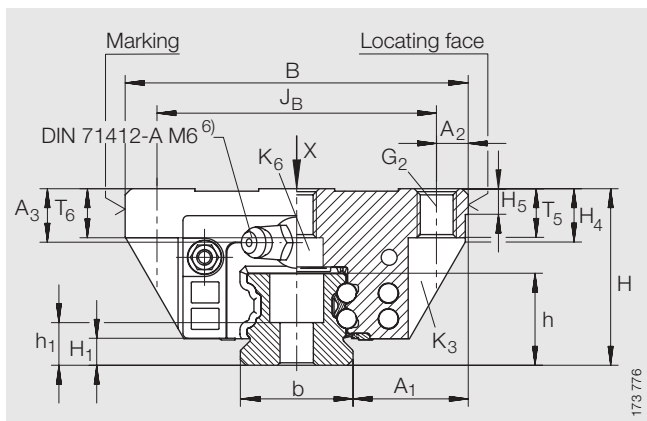

KUVE..B (L)

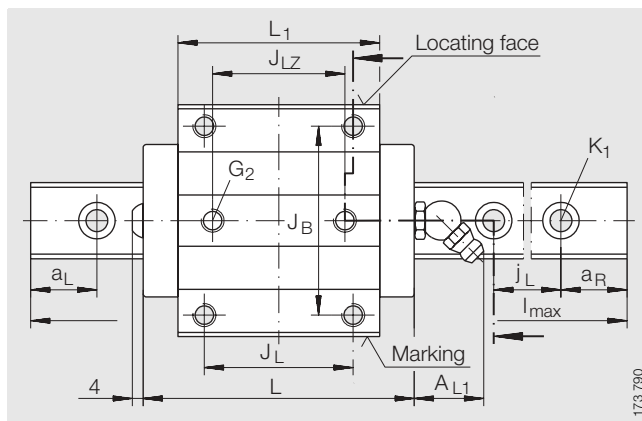

KUVE..B (L) · View X (rotated 90°)

															Fixing screws ³⁾⁴⁾							
L ₁	J _L	J _{LZ}	j _L	a _L /a _R ²⁾		A _{L1}	H ₁	H ₄	H ₅	A ₃	T ₅	T ₆	t ₇	h	h ₁	G ₁	G ₂	K ₁	K ₃	K ₆	K ₆	
				min.	max.											ISO 4762-12.9						DIN 7984-8.8
39,8	30	26	60	20	53	6,7	4,5	-	4,75	4	7	5,8	8	15	8,15	M5	M4	M4	M4	-	M4	
50,4	40	35	60	20	53	19	4,5	11	5	8	10	7,5	10	17	9,1	M6	M6	M5	M5	M5	-	
67,9								8,6		5	8	6		10	17	9,1	M6	M6	M5	M5	M5	-
50,4								8,6		5	8	6		10	17	9,1	M6	M6	M5	M5	M5	-
67,9	45	40	60	20	53	19	5,4	10,9	5	11	10	10	12	18,7	8,7	M6	M8	M6	M6	M6	-	
60,7								9,3		6	8	10		18,7	8,7	M6	M8	M6	M6	M6	-	
86,5								9,3		6	8	10		18,7	8,7	M6	M8	M6	M6	M6	-	
86,5								9,3		6	8	10		18,7	8,7	M6	M8	M6	M6	M6	-	

KUVE..B

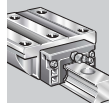

Load carrying capacity (for definition of basic load ratings, see INA Catalogue "605") ⁵⁾					
Unit Designation	Basic load ratings		Moment ratings		
	C N	C ₀ N	M _{0x} Nm	M _{0y} Nm	M _{0z} Nm
KUVE 15 B	7 200	14 500	150	100	100
KUVE 20 B	13 100	27 000	332	240	240
KUVE 20 B L	16 200	36 500	452	430	430
KUVE 20 B N	13 100	27 000	332	240	240
KUVE 20 B NL	16 200	36 500	452	430	430
KUVE 25 B	17 900	37 000	510	395	395
KUVE 25 B L	23 400	54 000	745	825	825
KUVE 25 B N	17 900	37 000	510	395	395
KUVE 25 B NL	23 400	54 000	745	825	825

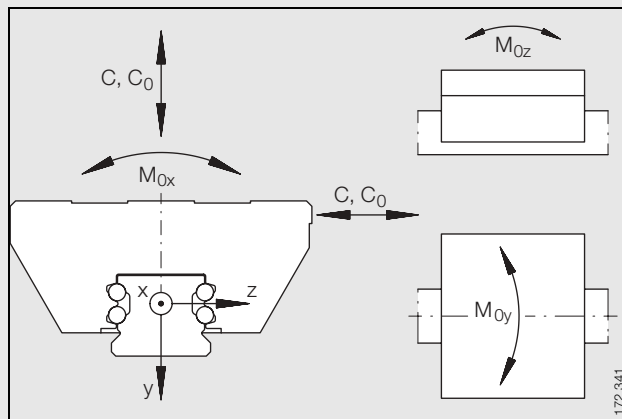

Load direction

Four-row linear recirculating ball bearing and guideway assemblies

full complement

Series KUVE..B SL
KUVE..B HL
KUVE..B SNL

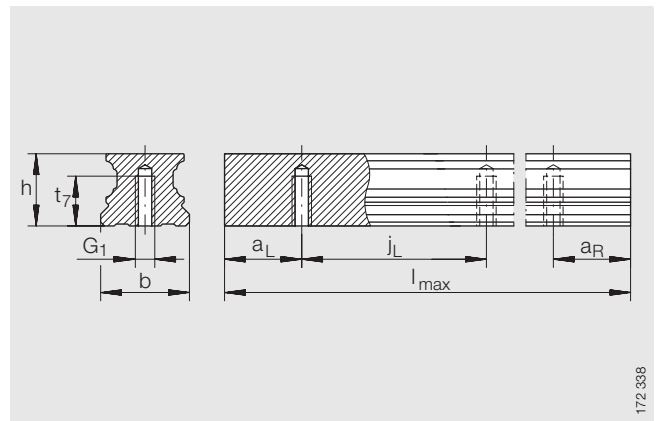

TKVD..U

Dimension table - Dimensions in mm

Unit Designation	Carriage		Guideway			Dimensions				Mounting dimensions			
	Designation	Mass m ≈kg	Designation	Mass m ≈kg/m	Closing plug K ₂	<i>l</i> _{max} ¹⁾	H	B	L	A ₁	J _B	b -0,005 -0,03	A ₂
KUVE 20 B SL	KWVE 20 B SL	0,46	TKVD 20 (U)	2,2	KA 10 TN A	1980	30	44	87,3	12	32	20	6
KUVE 20 B SNL	KWVE 20 B SNL	0,38					27						
KUVE 25 B HL	KWVE 25 B HL	0,95	TKVD 25 (U)	2,7	KA 11 TN A	1980	40	48	107,5	12,5	35	23	6,5
KUVE 25 B SL	KWVE 25 B SL	0,63					36						
KUVE 25 B SNL	KWVE 25 B SNL	0,65					31						

- 1) Maximum length of single-piece guideways; longer guideways are supplied in several sections and are marked accordingly. Maximum single-piece guideway length of 6 m by agreement.
- 2) *a*_L and *a*_R are dependent on the guideway length, *Calculation*, page 31.
- 3) If there is a possibility of settling, the fixing screws should be secured against rotation.
- 4) For information on fixing screws see *INA Catalogue "605", Fixing screws*.
- 5) Calculation of basic load ratings in accordance with DIN 636. Based on practical experience, it may be possible to increase the basic dynamic load rating.
- 6) Lubrication nipple with tapered head to DIN 71412-B M6, except for KUVE 20 B... to DIN 71412-B M5 and KUVE 15 B... to DIN 3405 M3.

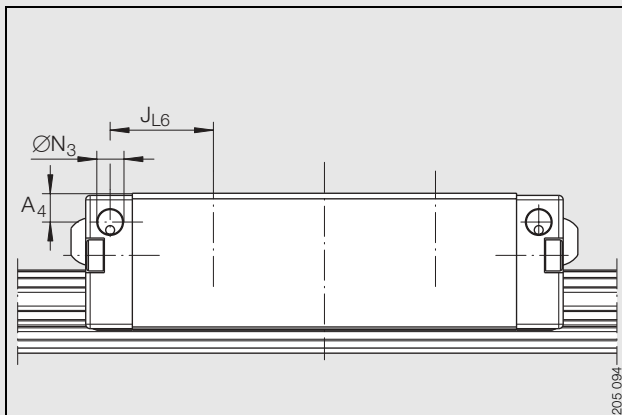

Lateral lubrication connector

Dimensioning of lateral lubrication connector

Designation	ØN ₃	A ₄	J _{L6}
KUVE 20 B SL	4,7	4,6	13,2
KUVE 20 B SNL	2,7	3,3	13,2
KUVE 25 B HL	5,6	10,5	23,3
KUVE 25 B SL	5,6	6,5	23,3
KUVE 25 B SNL	2,7	4	22,5

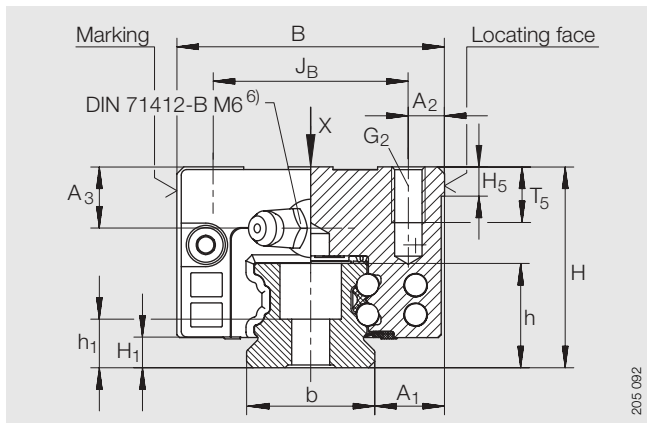

KUVE..B SL (N)

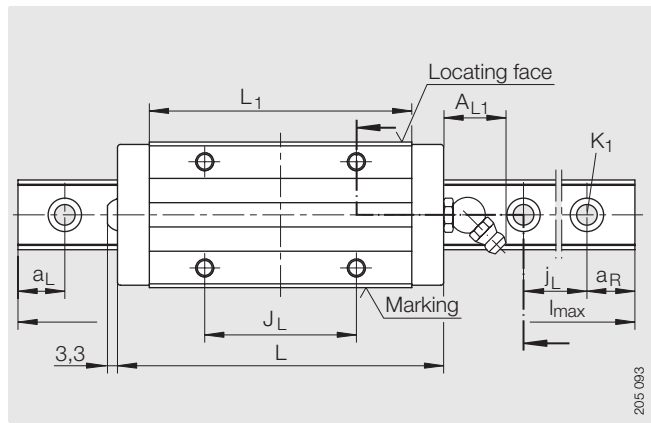

KUVE..B SL (N) · View X (rotated 90°)

L ₁	J _L	j _L	a _L /a _R ²⁾		A _{L1}	H ₁	H ₅	A ₃	T ₅	T ₆	t ₇	h	h ₁	Fixing screws ³⁾⁴⁾		
			min.	max.										G ₁	G ₂	K ₁
67,9	50	60	20	53	19	4,5	5	8	7,5	-	10	17	9,1	M6	M5	M5
								5		7,5						
86,5	50	60	20	53	19	5,4	5	15	16	-	12	18,7	8,7	M6	M8	M6
								11								
								6								

KUVE..B

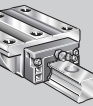

Load carrying capacity

(for definition of basic load ratings, see INA Catalogue "605")⁵⁾

Unit Designation	Basic load ratings		Moment ratings		
	C N	C ₀ N	M _{0x} Nm	M _{0y} Nm	M _{0z} Nm
KUVE 20 B SL	16 200	36 500	452	430	430
KUVE 20 B SNL	16 200	36 500	452	430	430
KUVE 25 B HL	23 400	54 000	745	825	825
KUVE 25 B SL	23 400	54 000	745	825	825
KUVE 25 B SNL	23 400	54 000	745	825	825

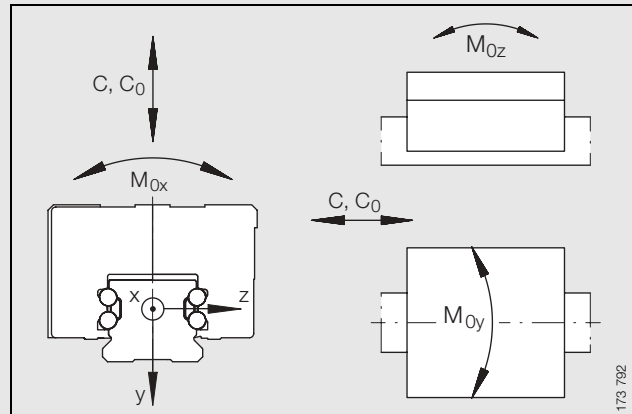

Load directions

173 792

Four-row linear recirculating ball bearing and guideway assemblies

full complement

Series KUVE..B H
KUVE..B S
KUVE..B SN

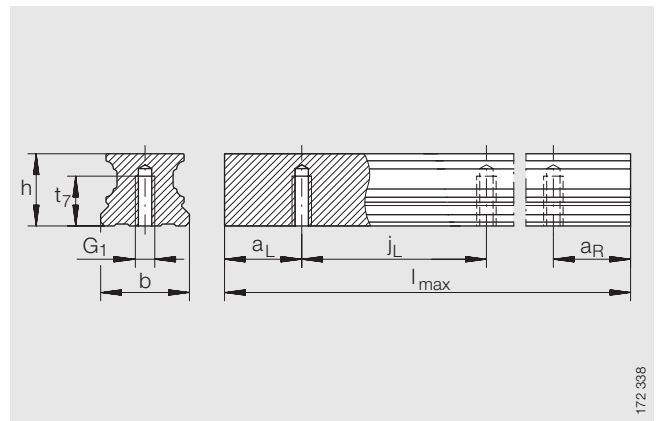

TKVD..U

Dimension table · Dimensions in mm

Unit Designation	Carriage		Guideway			Dimensions				Mounting dimensions		
	Designation	Mass m ≈kg	Designation	Mass m ≈kg/m	Closing plug K ₂	l _{max} ¹⁾	H	B	L	A ₁	J _B	b -0,005 -0,03
KUVE 15 B H	KWVE 15 B H	0,23	TKVD 15 B (U) ⁷⁾	1,44	KA 07 TN A	1200	28	34	59,6	9,5	26	15
KUVE 15 B S	KWVE 15 B S	0,19					24					
KUVE 20 B S	KWVE 20 B S	0,46	TKVD 20 (U)	2,2	KA 10 TN A	1980	30	44	69,8	12	32	20
KUVE 20 B SN	KWVE 20 B SN	0,36					27					
KUVE 25 B H	KWVE 25 B H	0,65	TKVD 25 (U)	2,7	KA 11 TN A	1980	40	48	81,7	12,5	35	23
KUVE 25 B S	KWVE 25 B S	0,56					36					
KUVE 25 B SN	KWVE 25 B SN	0,45					31					

- 1) Maximum length of single-piece guideways; longer guideways are supplied in several sections and are marked accordingly. Maximum single-piece guideway length of 6 m by agreement.
- 2) a_L and a_R are dependent on the guideway length, *Calculation*, page 31.
- 3) If there is a possibility of settling, the fixing screws should be secured against rotation.
- 4) For information on fixing screws see *INA Catalogue "605", Fixing screws*.
- 5) Calculation of basic load ratings in accordance with DIN 636. Based on practical experience, it may be possible to increase the basic dynamic load rating.
- 6) Lubrication nipple with tapered head to DIN 71412-B M6, except for KUVE 20 B..: to DIN 71412-B M5 and KUVE 15 B..: to DIN 3405 M3.
- 7) The new carriages cannot be used on the existing guideways TKVD 15 (U).

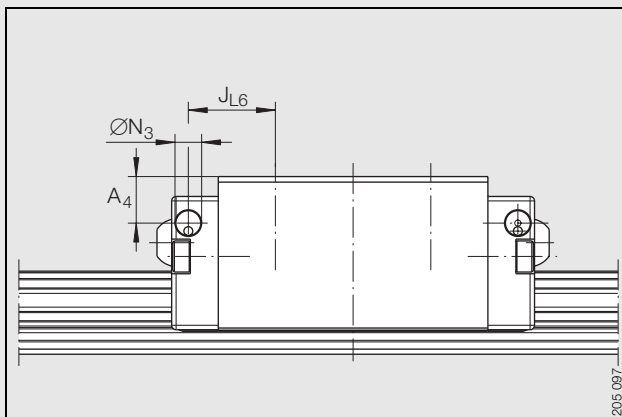

Lateral lubrication connector

Dimensioning of lateral lubrication connector

Designation	ØN ₃	A ₄	JL ₆
KUVE 15 B H	2,7	7,2	11,1
KUVE 15 B S	2,7	3,2	11,1
KUVE 20 B S	4,7	4,6	11,4
KUVE 20 B SN	2,7	3,3	11,4
KUVE 25 B H	5,6	10,5	17,9
KUVE 25 B S	5,6	6,5	17,9
KUVE 25 B SN	2,7	4	17,1

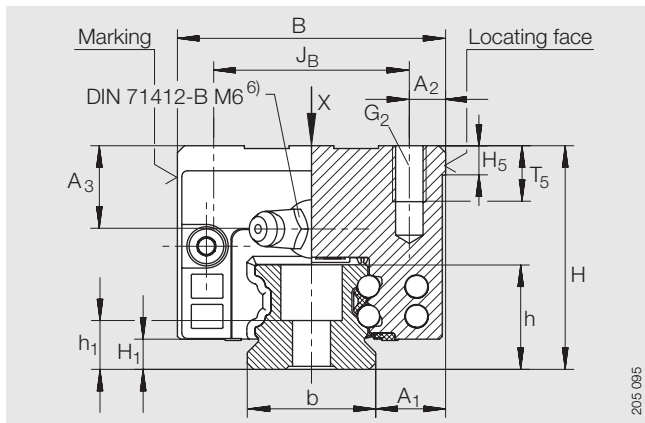

KUVE..B H (S, SN)

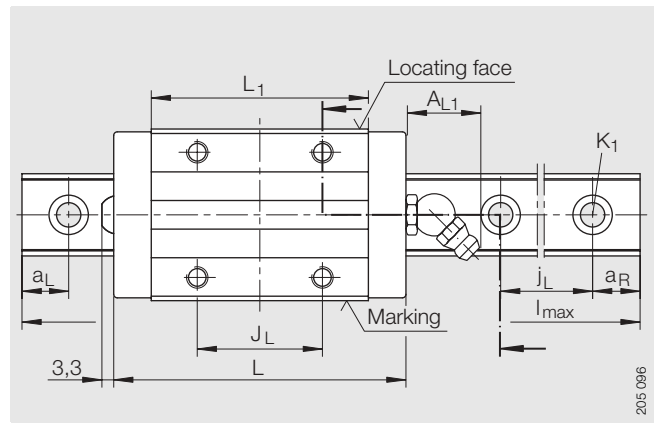

KUVE..B H (S, SN) · View X (rotated 90°)

A ₂	L ₁	J _L	j _L	a _L /a _R ²⁾		A _{L1}	H ₁	H ₅	A ₃	T ₅	t ₇	h	h ₁	Fixing screws ³⁾⁴⁾		
				min.	max.									G ₁	G ₂	K ₁
4	39,8	26	60	20	53	6,7	4,5	4,75	8 4	6	8	15	8,15	M5	M4	M4
6	50,4	36	60	20	53	19	4,5	5	8 5	7,5	10	17	9,1	M6	M5	M5
6,5	60,7	35	60	20	53	19	5,4	5	15 11 6	10 10 7,5	12	18,7	8,7	M6	M8	M6

KUVE..B

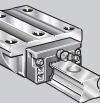

Load carrying capacity

(for definition of basic load ratings, see INA Catalogue "605")⁵⁾

Unit Designation	Basic load ratings		Moment ratings		
	C N	C ₀ N	M _{0x} Nm	M _{0y} Nm	M _{0z} Nm
KUVE 15 B H	7 200	14 500	150	100	100
KUVE 15 B S	7 200	14 500	150	100	100
KUVE 20 B S	13 100	27 000	332	240	240
KUVE 20 B SN	13 100	27 000	332	240	240
KUVE 25 B H	17 900	37 000	510	395	395
KUVE 25 B S	17 900	37 000	510	395	395
KUVE 25 B SN	17 900	37 000	510	395	395

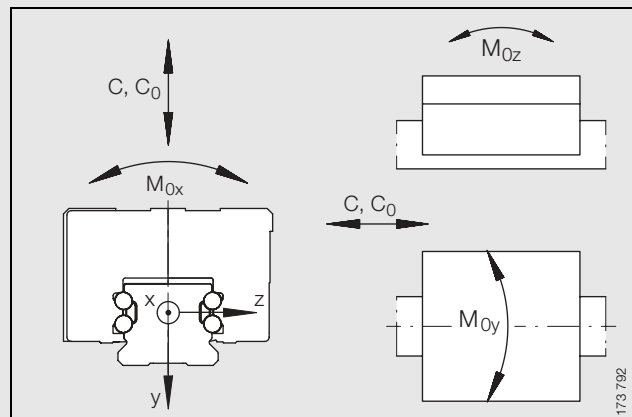

Load directions

Four-row linear recirculating ball bearing and guideway assemblies

full complement

Series KUVE..B E C

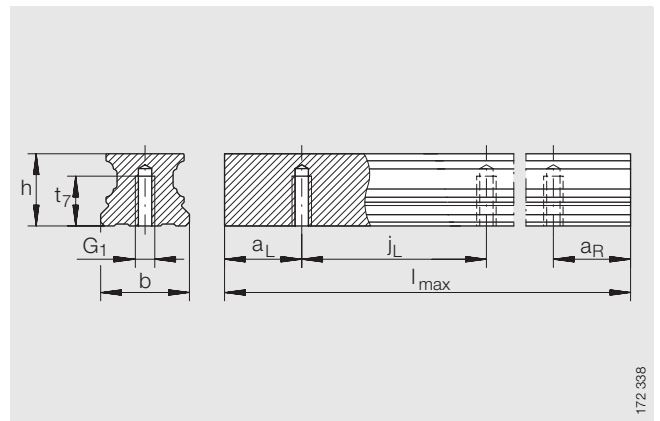

TKVD..U

Dimension table · Dimensions in mm

Unit Designation	Carriage		Guideway			Dimensions				Mounting dimensions		
	Designation	Mass m ≈kg	Designation	Mass m ≈kg/m	Closing plug K ₂	l _{max} ¹⁾	H	B	L	A ₁	J _B	b -0,005 -0,03
KUVE 15 B E C	KWVE 15 B E C	0,26	TKVD 15 B (U) ⁷⁾	1,44	KA 07 TN A	1200	24	52	42,9	18,5	41	15
KUVE 20 B E C	KWVE 20 B E C	0,43	TKVD 20 (U)	2,2	KA 10 TN A	1980	28	59	69,8	19,5	49	20
KUVE 25 B E C	KWVE 25 B E C	0,47	TKVD 25 (U)	2,7	KA 11 TN A	1980	33	73	81,7	25	60	23

- 1) Maximum length of single-piece guideways; longer guideways are supplied in several sections and are marked accordingly. Maximum single-piece guideway length of 6 m by agreement.
- 2) a_L and a_R are dependent on the guideway length, *Calculation*, page 31.
- 3) If there is a possibility of settling, the fixing screws should be secured against rotation.
- 4) For information on fixing screws see *INA Catalogue "605", Fixing screws*.
- 5) Calculation of basic load ratings in accordance with DIN 636. Based on practical experience, it may be possible to increase the basic dynamic load rating.
- 6) Lubrication nipple with tapered head to DIN 71412-B M6, except for KUVE 20 B..: to DIN 71412-B M5 and KUVE 15 B..: to DIN 3405 M3.
- 7) The new carriages cannot be used on the existing guideways TKVD 15 (U).

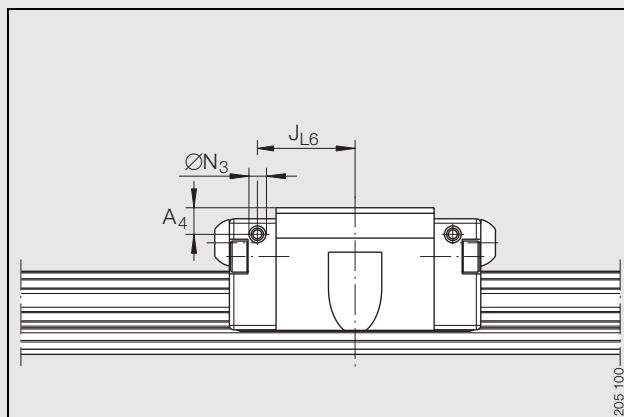

Lateral lubrication connector

Dimensioning of lateral lubrication connector

Designation	ØN ₃	A ₄	J _{L6}
KUVE 15 B E C	2,7	3,2	15,8
KUVE 20 B E C	2,7	4,3	18,9
KUVE 25 B E C	2,7	6	22

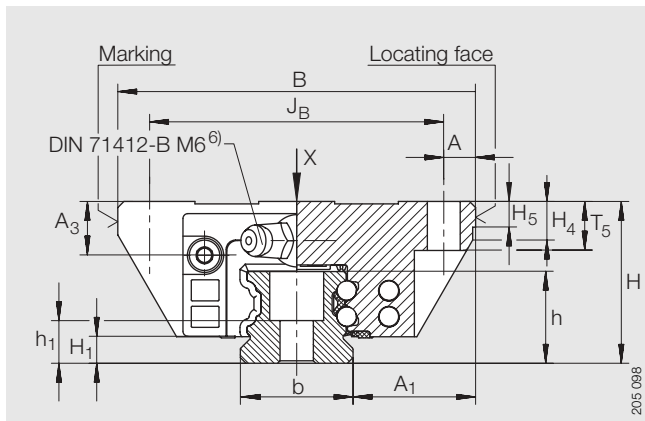

KUVE..B E C

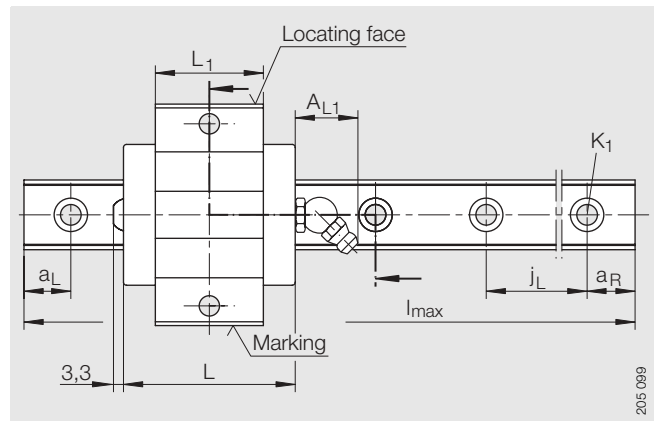

KUVE..B E C · View X (rotated 90°)

A ₂	L ₁	J _L	j _L	a _L /a _R ²⁾		A _{L1}	H ₁	H ₄	H ₅	A ₃	T ₅	t ₇	h	h ₁	Fixing screws ³⁾⁴⁾			
				min.	max.										G ₁	G ₂	K ₁	K ₃
5,5	23,1	26	60	20	53	6,7	4,5	6,1	4,75	4	7	8	15	8,15	M5	M4	M4	-
5	50,4	32	60	20	53	19	4,5	8,8	5	6	9	10	17	9,1	M6	-	M5	M5
6,5	36	-	60	20	53	19	5,4	7,85	5	8	10	12	18,7	8,7	M6	M6	M6	M6

KUVE..B

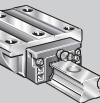

Load carrying capacity

(for definition of basic load ratings, see INA Catalogue "605")⁵⁾

Unit Designation	Basic load ratings		Moment ratings		
	C N	C ₀ N	M _{0x} Nm	M _{0y} Nm	M _{0z} Nm
KUVE 15 B E C	4 900	8 300	86	35	35
KUVE 20 B E C	8 900	15 400	190	85	85
KUVE 25 B E C	12 500	22 200	305	155	155

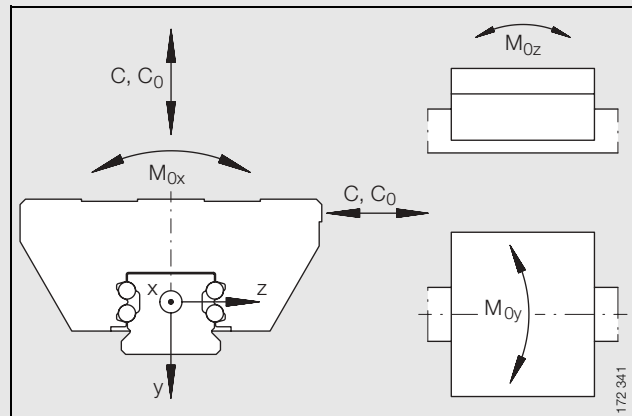

Load directions

Four-row linear recirculating ball bearing and guideway assemblies

full complement

Series KUVE..B E SC

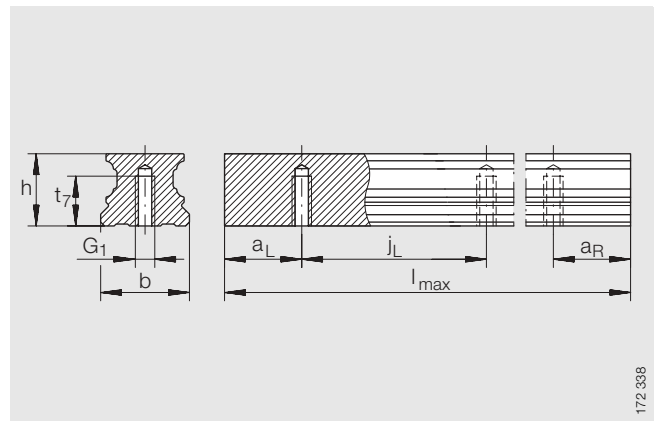

TKVD..U

Dimension table · Dimensions in mm

Unit	Carriage		Guideway			Dimensions				Mounting dimensions		
	Designation	Mass m ≈kg	Designation	Mass m ≈kg/m	Closing plug K ₂	<i>l</i> _{max} ¹⁾	H	B	L	A ₁	J _B	b -0,005 -0,03
KUVE 15 B E SC	KWVE 15 B E SC	0,17	TKVD 15 B (U) ⁷⁾	1,44	KA 07 TN A	1200	24	34	42,9	9,5	26	15
KUVE 20 B E SC	KWVE 20 B E SC	0,28	TKVD 20 (U)	2,2	KA 10 TN A	1980	28	59	48,8	11	32	20
KUVE 25 B E SC	KWVE 25 B E SC	0,35	TKVD 25 (U)	2,7	KA 11 TN A	1980	33	48	57	12,5	35	23

- 1) Maximum length of single-piece guideways; longer guideways are supplied in several sections and are marked accordingly. Maximum single-piece guideway length of 6 m by agreement.
- 2) *a_L* and *a_R* are dependent on the guideway length, *Calculation*, page 31.
- 3) If there is a possibility of settling, the fixing screws should be secured against rotation.
- 4) For information on fixing screws see *INA Catalogue "605", Fixing screws*.
- 5) Calculation of basic load ratings in accordance with DIN 636. Based on practical experience, it may be possible to increase the basic dynamic load rating.
- 6) Lubrication nipple with tapered head to DIN 71412-B M6, except for KUVE 20 B..: to DIN 71412-B M5 and KUVE 15 B..: to DIN 3405 M3.
- 7) The new carriages cannot be used on the existing guideways TKVD 15 (U).

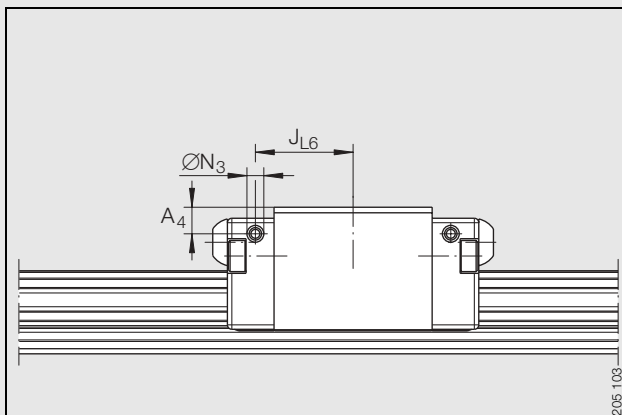

Lateral lubrication connector

Dimensioning of lateral lubrication connector

Designation	ØN ₃	A ₄	J _{L6}
KUVE 15 B E SC	2,7	3,2	15,8
KUVE 20 B E SC	2,7	4,3	18,9
KUVE 25 B E SC	2,7	6	22

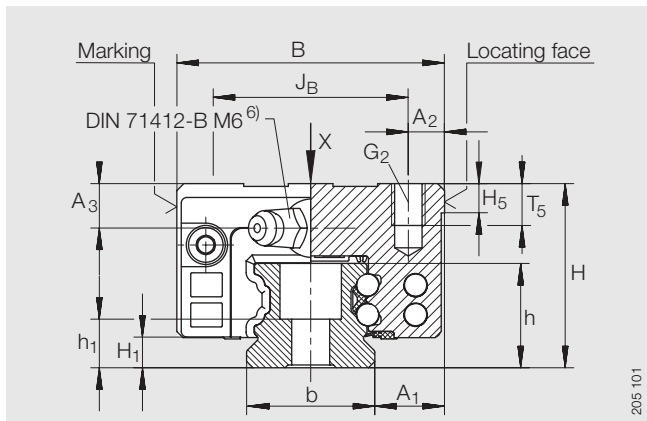

KUVE..B E SC

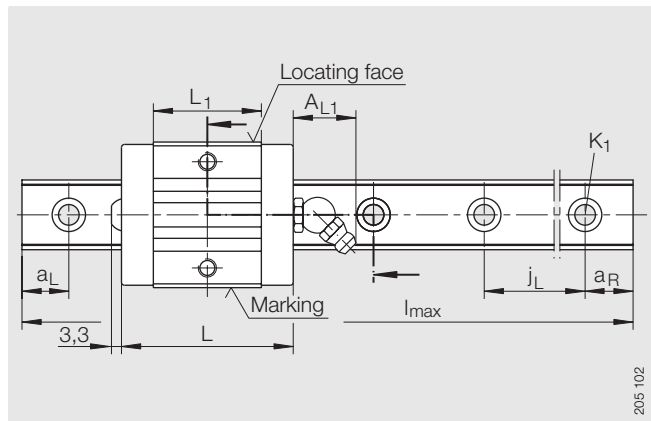

KUVE..B E SC · View X (rotated 90°)

													Fixing screws ³⁾⁴⁾			
A ₂	L ₁	j _L	a _L /a _R ²⁾		A _{L1}	H ₁	H ₅	A ₃	T ₅	t ₇	h	h ₁	G ₁	G ₂	K ₁	K ₃
			min.	max.									ISO 4 762-12.9			
5,5	23,1	60	20	53	6,7	4,5	4,75	4	7,5	8	15	8,15	M5	-	M4	-
5	29,4	60	20	53	19	4,5	5	6	7,5	10	17	9,1	M6	-	M5	M5
6,5	36	60	20	53	19	5,4	5	8	10	12	18,7	8,7	M6	M6	M6	M6

KUVE..B

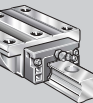

Load carrying capacity

(for definition of basic load ratings, see INA Catalogue "605")⁵⁾

Unit Designation	Basic load ratings		Moment ratings		
	C N	C ₀ N	M _{0x} Nm	M _{0y} Nm	M _{0z} Nm
KUVE 15 B E SC	4 900	8 300	86	35	35
KUVE 20 B E SC	8 900	15 400	190	85	85
KUVE 25 B E SC	12 500	22 200	305	155	155

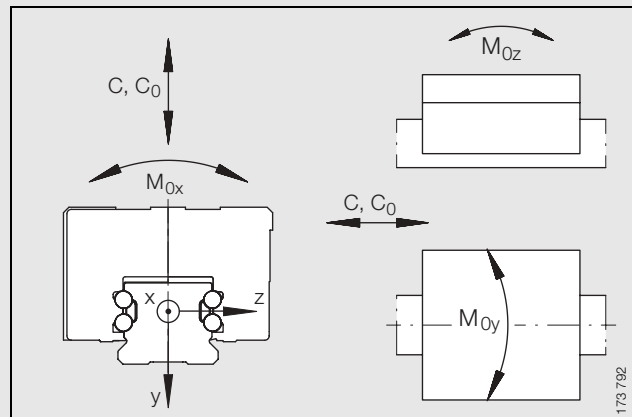

Load directions

Four-row linear recirculating ball bearing and guideway assemblies

with quad spacers or full complement



Preload

Linear recirculating ball guidance systems KUVE B (KT) are available in the preload classes in Table 1.

The preload class is determined by the carriage.

Influence of preload on the linear guidance system

Increasing the preload increases the rigidity. However, preload also influences the displacement resistance and operating life of linear guidance systems.

Table 1 · Preload classes

Preload class	Preload setting	Suitable applications
V0	Clearance-free to light clearance	<ul style="list-style-type: none"> ■ particularly smooth-running ■ moment loads
V1 ²⁾	$0,04 \cdot C^{1)}$	<ul style="list-style-type: none"> ■ moderate loads ■ high rigidity ■ moment loads
V2	$0,1 \cdot C^{1)}$	<ul style="list-style-type: none"> ■ high alternating loads ■ particularly high rigidity ■ moment loads

¹⁾ C is the basic dynamic load rating of the linear recirculating ball bearing and guideway assembly according to the *dimension table*.

²⁾ Standard preload class.



Friction

The coefficient of friction is dependent on the ratio C/P. For a guidance system without seals and with a load ratio of between C/P = 4 to C/P = 20, it is:

■ $\mu_{KUVE} = 0,0007$ to $0,0015$.



Accuracy

Accuracy classes of linear recirculating ball bearing and guideway assemblies

Four-row linear recirculating ball bearing and guideway assemblies are available in accuracy classes G1 to G4 (Figure 1).

The tolerances are arithmetic mean values. They relate to the centre point of the screw mounting or locating surfaces of the carriage. The dimensions H and A₁ (Table 2) should always remain within the tolerance irrespective of the position of the carriage on the guideway.

For accuracy class tolerances see Table 2, for reference dimensions see Figure 2.

Units with Corrotect® plating

For these units, the values for the appropriate accuracy class must be increased by the values for RRF or RRFT (for values see Table 2).

Table 2 · Accuracy class tolerances

Tolerance		Accuracy classes				With Corrotect® plating	
		G1 μm	G2 μm	G3 ⁴⁾ μm	G4 μm	RRF ²⁾ μm	RRFT ³⁾ μm
Height tolerance	H	± 10	± 20	± 25	± 80	+6	+3
Height difference ¹⁾	ΔH	5	10	15	20	+3	0
Distance tolerance	A ₁	± 10	± 15	± 20	± 80	+3	+3
Difference in distance ¹⁾	ΔA ₁	5	15	22	30	+3	0

¹⁾ Dimensional difference between several carriages on one guideway, measured at the same point on the guideway.

²⁾ Displacement in tolerance zone (guideway and carriage plated).

³⁾ Displacement in tolerance zone (guideway only plated).

⁴⁾ Standard accuracy class.

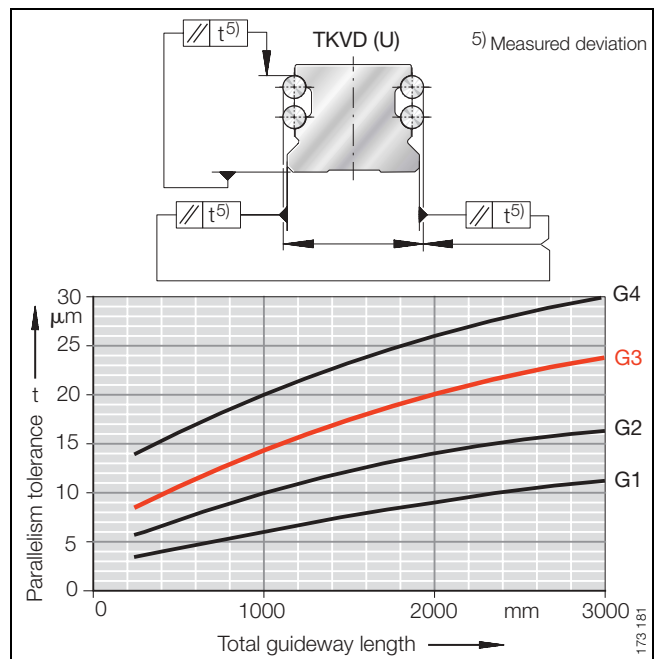

Figure 1 · Accuracy classes and parallelism tolerances of guideways

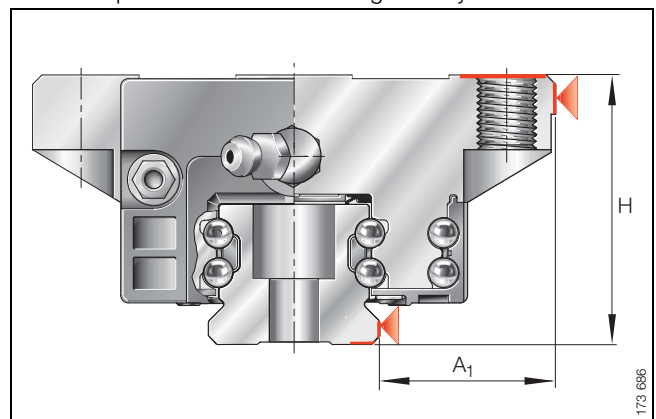

Figure 2 · Reference dimensions for accuracy



Four-row linear recirculating ball bearing and guideway assemblies

with quad spacers or full complement

Parallelism of raceways to locating surfaces

The parallelism tolerances of the guideways are shown in Figure 1.

For systems with Corrotect® plating, there may be deviations in tolerances compared with unplated units.

Positional tolerances of guideways

The positional tolerances are shown in Figure 3.

Length tolerances of guideways

For length tolerances, see Figure 3 and Table 3.

Table 3 · Length tolerances of guideways

Four-row linear ball bearing and guideway assembly	Tolerances of guideways, as a function of the length l_{max} ¹⁾			Multi-piece guideways
	l_{max}			
Designation	$\leq 1\,000$ mm	$> 1\,000$ mm $< 3\,000$ mm	$> 3\,000$ mm	
KUVE..B (KT)	-1 mm	-1,5 mm	$\pm 0,1\%$ of guideway length	± 3 mm over whole length

¹⁾ Length l_{max} : see dimension table.

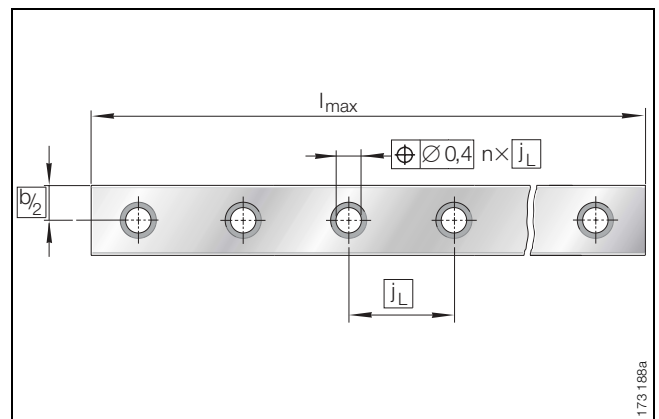

Figure 3 · Positional and length tolerances of guideways – hole pattern to ISO 1101

Hole pattern of guideways

Unless specified otherwise, the guideways have a symmetrical hole pattern.

An asymmetrical hole pattern may be available at customer request.

The following must be adhered to:

- $a_L \geq a_{Lmin}$ and $a_R \geq a_{Rmin}$ (Figure 4).

Maximum number of pitches between holes

The number of pitches between holes is the rounded whole number equivalent to:

$$n = \frac{l_{max} - (2 \cdot a_{Lmin})}{j_L}$$

The distances a_L and a_R are determined by:

$$a_L + a_R = l_{max} - n \cdot j_L$$

For guideways with a symmetrical hole pattern:

$$a_L = a_R = \frac{1}{2} \cdot (l_{max} - n \cdot j_L)$$

Number of holes:

$$x = n + 1$$

a_L, a_R mm
Distance between start or end of guideway and nearest hole

a_{Lmin}, a_{Rmin} mm
Minimum values for a_L, a_R according to the *dimension table*

l_{max} mm
Guideway length

n -
Maximum number of pitches between holes

j_L mm
Distance between holes

x -
Number of holes.

 The minimum and maximum values for a_{Lmin} and a_{Rmin} must be observed (*dimension table*), otherwise the counterbores may be intersected by the end of the guideway.

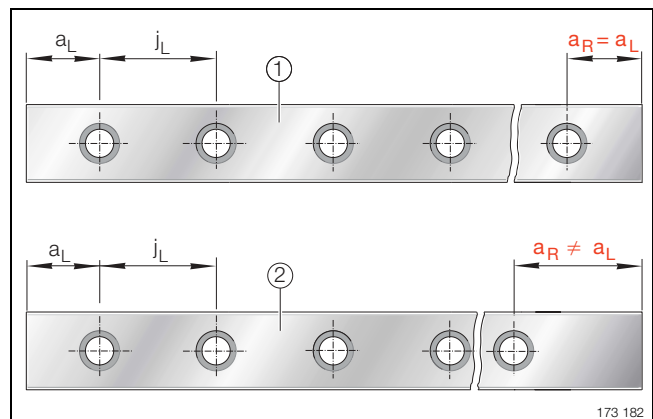

Figure 4 · Symmetrical ① and asymmetrical ② hole patterns for guideways with one row of holes

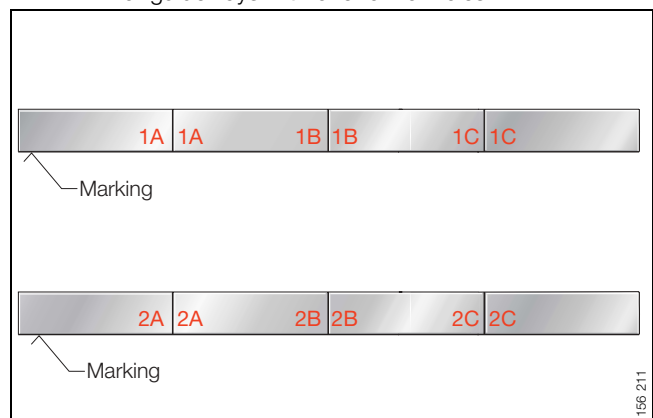

Figure 5 · Marking of multi-piece guideways

Multi-piece guideways

If the guideway length required is greater than l_{max} according to the *dimension table*, a guideway of the total length is made up from individual sections. The individual sections are matched to each other and marked accordingly (Figure 5).



Four-row linear recirculating ball bearing and guideway assemblies

with quad spacers or full complement



Demands on the adjacent construction

Running accuracy of linear guidance systems

The running accuracy is essentially dependent on the straightness, accuracy and rigidity of the fit and mounting surfaces. The straightness of the system is only achieved when a guideway is pressed against the datum surface.

If high demands are to be made on the running accuracy and/or if soft substructures and/or movable guideways are used, please consult INA.

Geometrical and positional accuracy of the mounting surfaces

The higher the requirements for accuracy and smooth running of the guidance system, the more attention must be paid to the geometrical and positional accuracy of the mounting surfaces.

- The tolerances in Figure 6 and Table 5 must be adhered to
- Surfaces should be ground or precision milled with the aim of achieving a mean roughness value of $R_a1,6$.



Deviations from the specified tolerances:

- will impair the overall accuracy of the guidance system
- will alter the preload
- will reduce the operating life of the guidance system.

Height difference ΔH

The permissible values for ΔH (Figure 6) are given by the formula below. If larger deviations are present, please consult the INA engineering service.

$$\Delta H = a \cdot b$$

ΔH μm

Maximum permissible deviation from the theoretically precise position

a -

Factor dependent on preload class (Table 4)

b mm

Centre distance between guidance elements.

Table 4 · Factor a – dependent on preload class

Preload class	Factor a
V	-
V0	-
V1 ¹⁾	0,2
V2	0,1

¹⁾ Standard preload class.

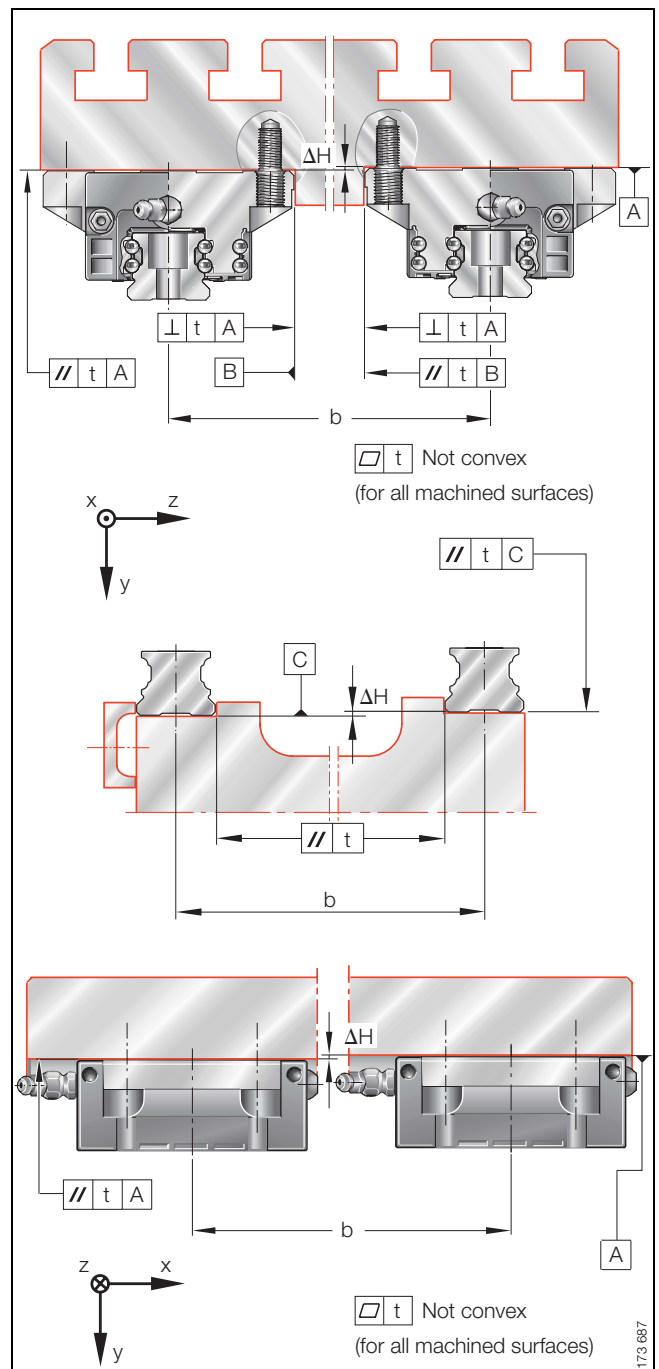

Figure 6 · Tolerances of mounting surfaces and parallelism of mounted guideways

Parallelism of mounted guideways

For guideways arranged parallel to each other, the parallelism value t given in Figure 6 and Table 5 should be adhered to.

If the maximum values are used, this may increase the displacement resistance. If larger tolerances are present, please consult INA.

Table 5 · Values for parallelism tolerances t

Guideway Designation	Preload class		
	V0	V1	V2
	Parallelism tolerance		
	t μm	t μm	t μm
TKVD 15 B (U)	11	8	5
TKVD 20 (U)	13	9	6
TKVD 25 (U)	17	11	7



Four-row linear recirculating ball bearing and guideway assemblies

with quad spacers or full complement

Locating heights and corner radii

Locating heights and corner radii should be in accordance with Figure 7 and Table 6.

Table 6 · Locating heights and corner radii

Linear recirculating ball bearing and guideway assembly Designation	h_1	h_2 max.	r_1 max.	r_2 max.
KUVE 15 B (H, S, E C, E SC)	4,5	3,5	1	0,5
KUVE 15 B KT (L, H, HL, S, SL)	4,5	3,5	1	0,5
KUVE 20 B (L, S, SL, SN, SNL, N, NL, E C, E SC)	5	4	1	0,5
KUVE 20 B KT (L, S, SL)	5	4	1	0,5
KUVE 25 B (L, H, HL, S, SL, SN, SNL, N, NL, E C, E SC)	5	4,5	1	0,8
KUVE 25 B KT (L, H, HL, S, SL)	5	4,5	1	0,8

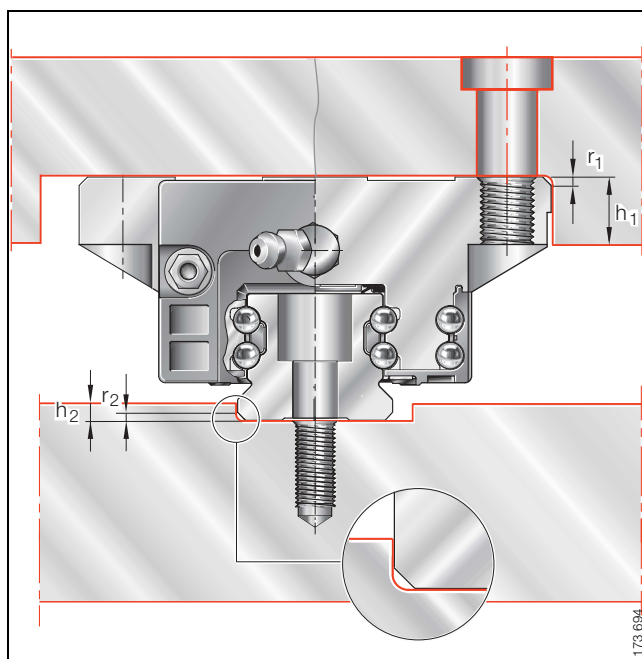

Figure 7 · Locating heights and corner radii

Sales company Engineering service

Sales company

INA-Schaeffler KG
Linear Technology Division
66406 Homburg (Saar)
Postal address:
Berliner Straße 134
66424 Homburg (Saar)
Tel. (0 68 41) 7 01-0
Fax (0 68 41) 7 01-625
E-Mail info.linear@de.ina.com



Engineering service

Northern Region

Northern Regional Office

Postfach 10 03 32
40767 Monheim
Postal address:
An der Alten Ziegelei 1
40789 Monheim
Tel. (0 21 73) 95 24-0
Fax (0 91 32) 82 45 96 04

Engineering Office – Rhein-Ruhr

Fax (0 91 32) 82 45 96 02

Engineering Office – Siegen

Fax (0 91 32) 82 45 96 03

Automotive Office – Monheim

Fax (0 91 32) 82 45 96 04

Technical Office and Linear Technology – Monheim

Fax (0 91 32) 82 45 96 05

Engineering Office – Berlin

Cunostraße 64
14193 Berlin
Tel. (0 30) 8 26 40-51/-52
Fax (0 30) 8 26 64 60

Engineering Office – Bielefeld

Gottlieb-Daimler-Straße 2–4
33803 Steinhausen
Tel. (0 52 04) 9 99-5 00
Fax (0 52 04) 9 99-5 01

Engineering Office – Hamburg

Pascalköhe 13
25451 Quickborn
Tel. (0 41 06) 7 30 83
Fax (0 41 06) 7 19 77

Engineering Office – Hanover

Automotive Office – Hanover

Technical Office and Linear Technology – Hanover

Postfach 81 03 29
30503 Hannover
Postal address:
Hildesheimer Straße 284
30519 Hannover
Tel. (05 11) 98 46 99-0
Fax (05 11) 8 43 71 26

Central Region

Central Regional Office

Gutenbergstraße 13
63110 Rodgau-Jügesheim
Tel. (0 61 06) 85 06-0
Fax (0 61 06) 85 06-49

Engineering Office – Offenbach

Tel. (0 61 06) 85 06-41
Fax (0 61 06) 85 06-49

Technical Office and Linear Technology – Central Region

Tel. (0 61 06) 85 06-50
Fax (0 61 06) 85 06-54

Engineering Office – Nuremberg

Industriestraße 1–3
91074 Herzogenaurach
Tel. (0 91 32) 82-23 47
Fax (0 91 32) 82-49 30

Engineering Office – Chemnitz

Rabensteiner-Center
Oberfrohnauer Straße 62
09117 Chemnitz
Tel. (03 71) 8 42 72-0
Fax (03 71) 8 42 72-15

Technical Office and Linear Technology – Chemnitz

Tel. (03 71) 8 42 72-31
Fax (03 71) 8 42 72-15

Southern Region

Southern Regional Office

Engineering Office – Stuttgart

Untere Waldplätze 32
70569 Stuttgart
Tel. (07 11) 6 87 87-0
Fax (07 11) 6 87 87-10

Automotive Office – Southern Region

Technical Office – Southern Region

Engineering Office – Lahr

Postfach 17 60
77907 Lahr
Postal address:
Rheinstraße 17
77933 Lahr
Tel. (0 78 21) 58 42 37
Fax (0 78 21) 5 15 71

Engineering Office – Munich

Automotive Office – Munich

Technical Office and Linear Technology – Munich

Lackerbauerstraße 28
81241 München
Tel. (0 89) 89 60 74-0
Fax (0 89) 89 60 74-20



INA-Schaeffler KG

Linear Technology Division
66406 Homburg (Saar) · Germany

Internet www.ina.com

E-Mail info.linear@de.ina.com

In Germany:

Telephone 0180/5 00 38 72

Fax 0180/5 00 38 73

From other countries:

Telephone +49/68 41/7 01-0

Fax +49/68 41/7 01-6 25



Welcome to the
double world class
of INA & FAG



Partner Power

X-life – this is the new premium grade from INA and FAG, offering you new opportunities for success. Benefit from the combined expertise of two rolling bearing manufacturers with a worldwide reputation – in every area of application covering automotive, machine building and precision engineering.

INA and FAG have brought together their strengths to give a new dimension in quality:

X-life.

Higher cost-effectiveness.

Higher operational security.

Welcome to the double world class
of INA & FAG



A Member of the
Schaeffler Group



Welcome to the double world class of INA & FAG



What X-life offers:

X-life offers excellent product quality that far exceeds previous standards.

Furthermore, X-life optimises all the parameters that are decisive for a problem-free production cycle. This includes correct fitting and dismantling, maintenance intervals matched to the specific application and the selection of lubricants matched to operating conditions.

A further convincing advantage of X-life is product characteristics that fulfil your specific requirements and offer additional benefits: for example, particularly low-noise, maintenance-friendly or high load capacity system solutions.

Your X-life advantages at a glance:

- product characteristics far above the norm
- lasting quality assurance and control
- extremely high reliability
- even greater security in planning and systems
- optimum availability
- smooth-running working processes
- reduced energy consumption
- the maximum possible cost-effectiveness
- the maximum possible level of service and support



A Member of the
Schaeffler Group