

Szczotki z włosiem nylonowym (VSN) i ze stali nierdzewnej (VSS)

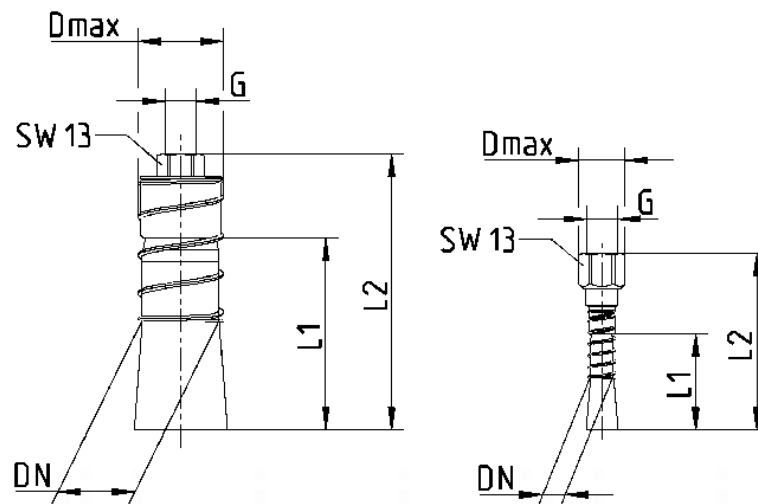

	Oznaczenie	DN	L1	L2	Dmax
	VSN-S6 VSS-S6	6	30	52	15
	VSN-S16 VSS-S16	16	60	81	20
	VSN-S25 VSS-S25	25	60	86	28

	VSN-S30 VSS-S30	32	70	96	35
	VSN16 VSS16	16	30	51	18
	VSN25 VSS25	25	45	71	28
	VSN30 VSS30	32	45	71	35

Trzpienie do szczotek

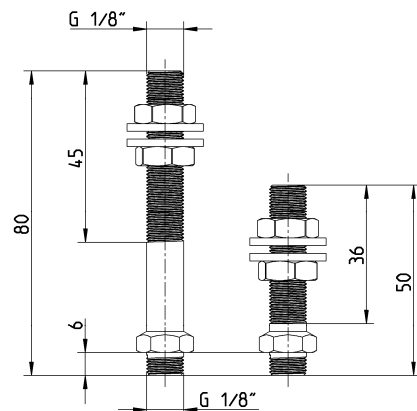

Uchwyt szczotki

